



GTR eco SERIES(0.1kW~2.2kW)

IPM gearmotor

Detailed Instruction Manual

<Please read this manual before using the product.>

Contents of this manual is based on using with our specialized inverter.

When operating with other inverters, make sure to check

「14. Notes on operating with inverters other than the specialized inverter」.



Nissei Corporation



Introduction

Thank you very much for purchasing our product.

Safety Precautions

- Be sure to carefully read the contents described in this instruction manual and to understand how to use product correctly before using it.
- The extent of hazard/damage expected to occur in the case of improper handling are classified and indicated in ranks of "DANGER", "WARNING", and "CAUTION." The definitions and indications are as follows.









■ Description of symbols















 Danger	Cases where it is expected that a degree of danger is extremely high such that improper handling possibly causes a dangerous situation to occur, which may lead to death or serious injury.
 Warning	Cases where improper handling possibly causes a dangerous situation to occur, which may lead to death or serious injury.
 Caution	Cases where improper handling possibly causes a dangerous situation to occur, from which a minor or medium degree of injury may be incurred.

Even items described in "CAUTION" may lead to a serious results depending on the situation.











Be sure to observe every instruction which deals with important contents.

■ The types of contents to be observed are explained with classification by graphical symbols below.

	Indicates "What You Must Pay Attention To."		Indicates "What You Must Not Do."
	Indicates "Burn Hazard."		Indicates "Do Not Disassemble."
	Indicates "Electric Shock Hazard."		Indicates "What You Must Do."
	Indicates "Fire hazard."		Indicates "Ground Connection."

 DANGER	
 	IPM motors cannot be driven with a commercial power supply. If commercial power supply is applied to the input terminals(U, V, W) of motor, the motor will be burned. Always connect them to the output terminals(U, V, W) of the driver compatible with PM motor.
 	Use an explosion-proof motor that complies with operation under the explosive atmosphere. Failure to follow this precaution may result in explosions, ignition of fire, fire, electric shocks, injuries, and/or damage to the application.
 	If the product is used in an application such as a personnel transport device, make sure to install a protective device for safety purposes. Failure to implement safety measures may result in personal injury, death, and/or damage to the application.
 	If the product is used in an elevator, install a safety device on the application to prevent it from falling. Failure to implement safety measures may result in personal injury, death, and/or damage to the application due to the falling of the elevator.
 	Do not perform wiring as voltage is generated at the motor terminals, while the motor is running, even when the power has been turned off. Otherwise, an electric shock may occur.
 	Never perform operations with wet hands. Failure to follow this precaution may result in electric shock.
 	Do not come close or touch the rotating parts (output shafts, etc.) while the product is in operation. Failure to follow this precaution may result in injury due to entanglement.

⚠ WARNING

		The operators in charge of transportation, installation, wiring, operation, handling, maintenance, and inspection should have enough knowledge and technical skill related to the product. Failure to follow this precaution may result in explosion, ignition of fire, fire, electric shock, injury, and/or damage to the application.
		When the operation has stopped due to the occurrence of error or activated safeguards, do not re-start the operation until the causes of error are determined and countermeasures are taken. Failure to follow this precaution may result in damage to the application, injury, fire, electric shock, and/or burns.
		Do not repair, disassemble or remodel the product. Failure to observe this precaution may result in injury, fire, electric shock, and/or burns.
		When performing trial operation, fix the product in place and disconnect it from the application. Failure to observe this precaution may result in injury.
		Be sure not to get water or oil/grease into the brake unit. Failure to follow this precaution may result in falling or out-of-control accident due to the decreased brake torque.

⚠ CAUTION

		The product must be transported correctly in accordance with its weight.
		Do not overload/over stack the products. Failure to follow this precaution may result in injury and/or equipment failure.
		When handling the gearmotor, be careful with the sharp edges/points of the application. Failure to follow this precaution may result in injury.
		Fix the gearmotor firmly in place. Failure to follow this precaution may result in damage to the equipment or injury.
		Do not touch the gearmotor when the power is on or immediately after turning off the power, as their surfaces may be hot for a while. Failure to follow this precaution may cause burns.
		Immediately stop the operation if there is any abnormality. Failure to follow this precaution may result in fire, and/or injury.
		Do not put any combustible material near the product. Failure to follow this precaution may result in fire.
		Operate the product under the conditions specified in this instruction manual. Failure to follow this precaution may result in damage to the equipment or injury.
		Do not put any object that may prevent air from being circulated around the product. Failure to follow this precaution can cause abnormal overheating of the product. It may result in fire or burns.
		Do not stand on or place any heavy object on the product. Failure to follow this precaution may result in injury
		Be careful not to cause damage to the cable nor pull it strongly. Failure to follow this precaution may result in injury, fire, and/or electric shock.
		Do not expose the product to strong impacts/shocks. Failure to observe this precaution may result in failure of the product and/or injury.
		Make sure that the gearmotor is correctly wired. Failure to follow this precaution may result in injury due to damaged equipment.
		Do not touch the rotating part of the gearmotor. Failure to follow this precaution may result in injury.
		Do not use the gearmotor under conditions other than specified on the nameplate or the product specification. Failure to follow this precaution may result in electric shock, injury, fire, and/or damage to the application.
		Do not use damaged products. Failure to follow this precaution may result in injury, fire, and/or damage to the application.
		Do not remove the nameplate.

CAUTION



Products modified by a customer will not be covered by our warranty.



Do not insert fingers or objects in the open parts of the product. Failure to follow this precaution may result in electric shock, injury, fire, and/or damage to the application.

Important

When disposing of the product, dispose of it as a general industrial waste. Please follow local laws and regulations if any apply and take care of the waste accordingly.

Notice

We shall assume no responsibility or liability for any troubles caused by use that violates the cautions above.

The contents of this manual are subject to change without notice.

We have made every possible effort to make the contents of this manual easy to understand. If there is anything that is unclear or hard to understand, please feel free to contact us.

Table of Contents

Introduction	P.2
Safety Precautions	P.2
1. Inspection upon Unpacking	P.6
2. Transportation	P.9
3. Installation	P.9
4. Connecting with Other Equipment	P.11
5. Rotational Direction	P.18
6. Wiring	P.22
7. Operation • Specifications	P.27
8. Standards	P.29
9. Inspection and Adjustment	P.31
10. Troubleshooting	P.36
11. Disposal	P.37
12. Storage	P.37
13. Warranty	P.38
14. Notes on operating with inverters other than the specialized inverter	P.39
Contact Us	P.40

1. Inspection upon Unpacking

⚠ CAUTION



Check whether the product is consistent with your order.
Injury, damage to the application, etc. may occur if the wrong product is installed.



Check the top and bottom of the package before opening it. Failure to follow this precaution may result in injury.

1-1. Checking Package Contents

Check for the following items when unpacking the package.

Contact the dealer where you purchased the product or our nearest service office if you have any questions or if there are any defects.

- Is the information on the nameplate consistent with your order?
(Gearmotor Model, Reduction Ratio, Motor Capacity, Voltage, Frequency, etc.)
- Were any parts damaged during transportation?
- Are there any loose screws, bolts, and nuts?
- Are the accessories included in the package and consistent with the contents of the accessory statement?
(Accessory statement is not included if there is no accessories.)

1-2. Details of Nameplate

The following is a typical nameplate.

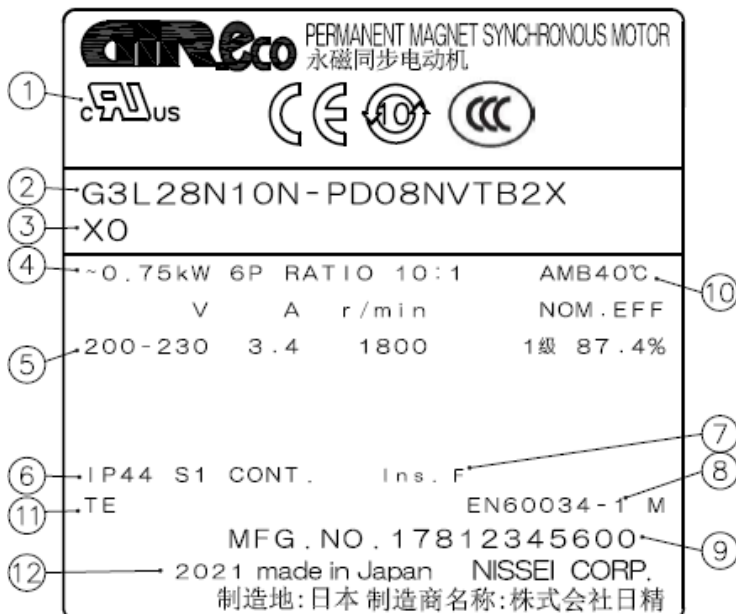

No.	Description
1	Compliant standards
2	Gearmotor model
3	Specification code
4	Capacity/No. of Poles/Reduction ratio
5	Motor characteristics
6	IP Rating
7	Insulation class
8	Standards number
9	Manufacturing number (MFG NO.)
10	Ambient temperature
11	Motor structure
12	Year of manufacture

- Please refer to the next page for the product name.
- The option code may not be listed.
- In the case of an inquiry, please provide the product name/option code, reduction ratio and MFG. NO.

1-3. Gearmotor Model

Descriptions of the symbols for gearmotor model are as follows. Check if the model is consistent with your order.
The gearhead model and motor model are described separately.

■ Gearhead Model

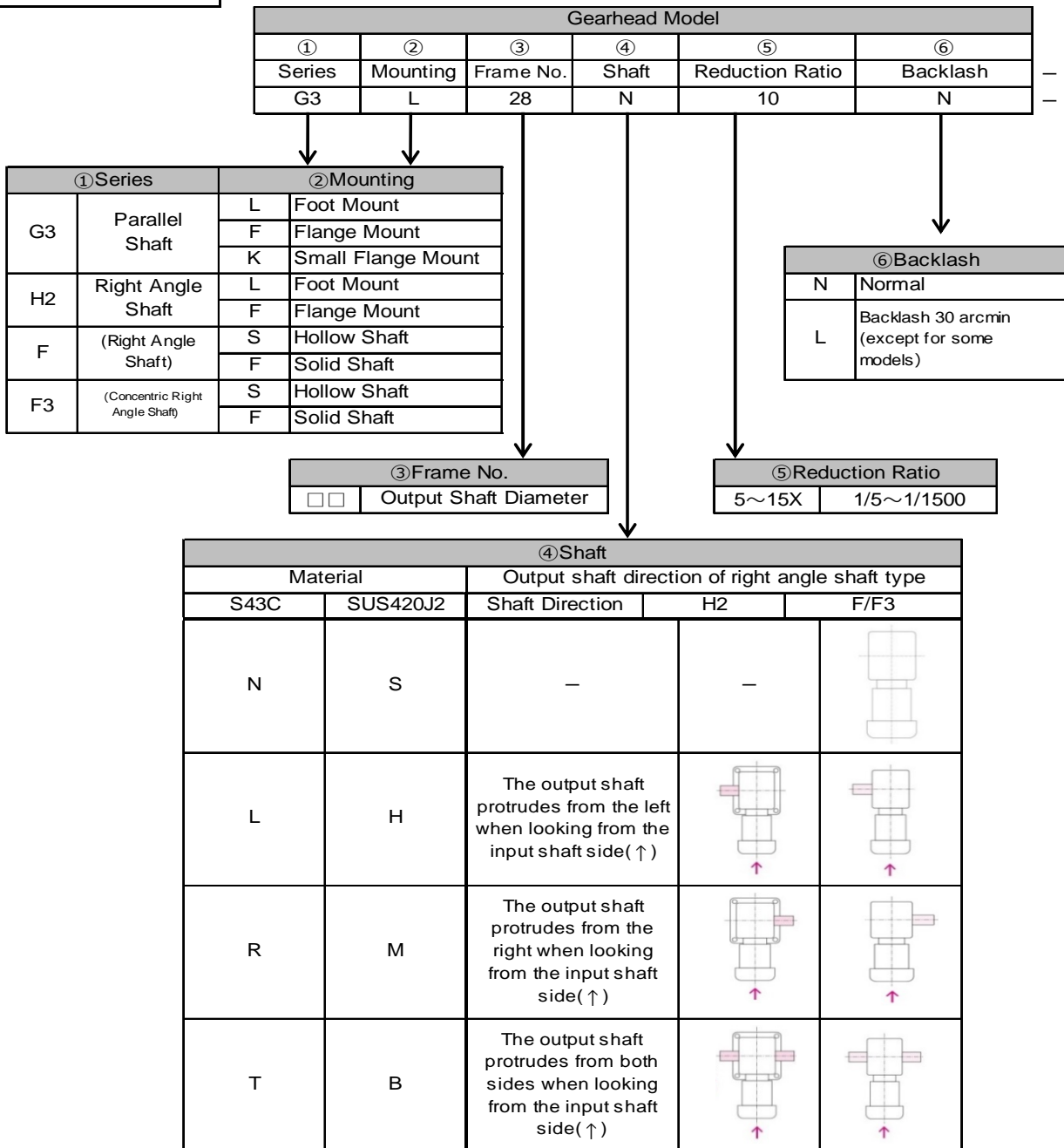

- Up to and including Frame No. 32 for ②Mounting K: Small flange support of ①Series G3 : Parallel shaft.
- Only Frame No. 22 for ②Mounting F: Flange support of ①Series H2 : Right angle shaft.
- Up to Capacity: 0.75 kW for ②Mounting F: Solid shaft of ①Series F : Right angle shaft.
- The ③Frame Number depends on the lineup of each series.
- ⑤Reduction ratios are 12X for 1200 and 15X for 1500 as they are displayed with up to three digits.

Motor Model

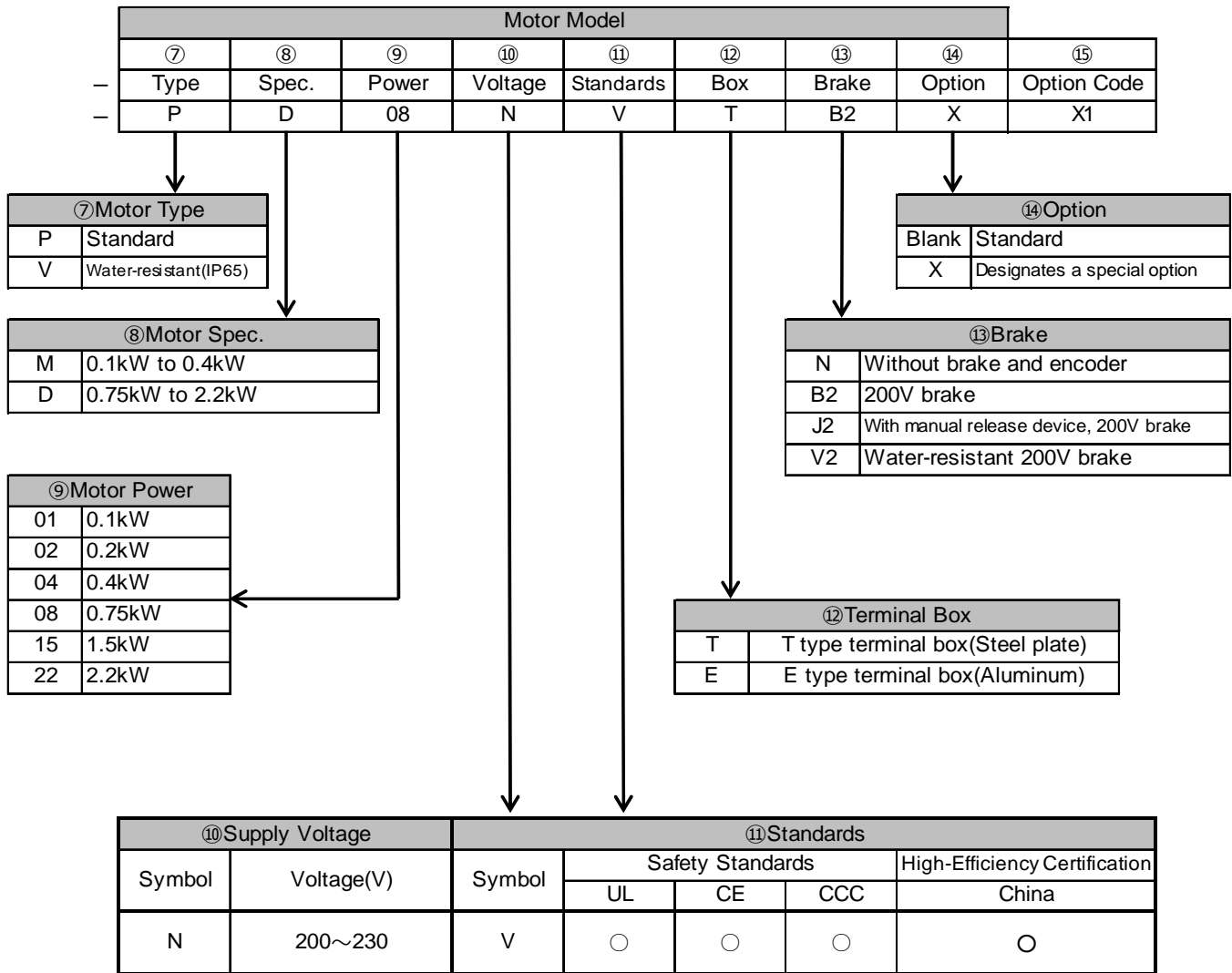

- CCC Standards[11] is supported for motor capacity of 0.1kW to 0.75kW.
- The motor capacity 0.75 kW or higher is supported for High-efficiency certification of Standards[11].
- Specification code[15] is added for options and special specifications. Main options are as follows.

Wiring instruction for terminal box with built-in rectifier, terminal box mounting orientation, change of lead wire outlet hole direction, encoder, fan installation, etc.

For more details regarding options, please refer to the catalog or contact us.

(Contact details described on the last page.)

2. Transportation

DANGER



Do not enter underneath the product when it is lifted for transportation. Otherwise, accidents caused by dropping may occur.

CAUTION



Dropping and falling of the product during transportation is dangerous. Please pay sufficient attention to prevent this. For a gearmotor with a hook, be sure to check that the hook is not loose before using it. However, do not lift the application with the hook of the attached gearmotor. Otherwise, hook damage, injury due to dropping/falling and application damage may occur.



Check the weight of the gearmotor with the nameplate, packaging box, appearance diagram, catalog, etc. Do not lift a gearmotor whose mass is more than the rated load of the ceiling/application hook. Otherwise, bolt damage, injury due to dropping/falling and application damage may occur.



If the package is made of wood, it is unstable to lift the package from the bottom when a lift is used. It is recommended to use a belt to hold the package when lifting.



Do not move the gearmotor by holding only the terminal box. Otherwise, injury and application damage may occur.

3. Installation

Pay attention to the following points as installation quality affects the lifespan of the gearmotor.

DANGER



Insulate the terminals when rotating the motor by turning the output shaft. Otherwise an electric shock may occur.

CAUTION



Do not place flammable items around the gearmotor. Otherwise, a fire may occur.



Do not place obstacles that disturb ventilation around the gearmotor. Cooling for the gearmotor may be disturbed and burn/fire may occur due to abnormal overheating.



Do not step on/hang from the gearmotor and terminal box. Otherwise, an injury may occur.



Do not touch gearmotor keyways with a bare hand. Otherwise, an injury may occur.



Install an oil pan for a food machinery and other applications in which leakage cannot be present and may occur in the event of a failure, service life, etc. Otherwise, products may be defective due to oil leakage.



Wear debris of the brake, iron powder (metal pieces), etc. may be scattered after continuous use. Mount a preventive device for food machinery and other applications which will result in defective products due to contamination of foreign substances. Otherwise, the product, etc. may be defective.



The guidance value of vibration from the mounting surface of the gearmotor or applied externally is 0.5 G or less.

⚠ CAUTION



Pay attention to the transportation atmosphere because dew condensation occurs easily on sea transportation. Dew condensation may occur inside of the box if the ambient temperature rapidly changes in a high temperature/humidity atmosphere.



Pay attention to freezing under temperatures of 0°C or lower as freezing may cause a short circuit between terminals. Otherwise, an electric shock may occur.

■ Location

Item	Standard specification	Water-resistant specification
Ingress protection	IP44	IP65
Ambient temperature	-10°C~40°C	-10°C~40°C
Ambient humidity	85%RH or less (no dew condensation)	100%RH or less (no dew condensation)
Altitude	1000 m or lower	1000 m or lower
Atmosphere	A well ventilated place free from corrosive gas, explosive gas, vapor and/or chemicals. Not to be exposed to rain and direct sunlight. The brake should not be exposed to water, powders, grease, and/or oil mists.	A place free from corrosive gas, explosive gas and/or vapor. Not to be exposed to strong rain, wind and direct sunlight. Not suitable for use under water, under environments with exposure to high pressure water splashes, and under exposure to cleansing chemicals.

■ Orientation

No restriction on installation orientation. (Since it uses a grease lubrication system)

■ Procedure

① Foot Mount, Flange Mount

Secure the gearmotor with four bolts on a vibration-free and flat machine-processed surface (0.3 mm or less of flatness).

② Shaft Mount (torque arm)

The drive shaft must be able to carry the weight of the reducer.

Note) Force other than the rotational reaction force should not be applied to the torque arm.

■ Tightening Torque for Installation Bolts (Reference value)

Mounting hole (mm)	Bolt size	Tightening torque	
		(N·m)	{(kgf·m)}
5.5	M5	2.9	{0.3}
6.5	M6	4.9	{0.5}
8.5	M8	13	{1.3}
9	M8	13	{1.3}
11	M10	25	{2.6}
13	M12	44	{4.5}
15	M14	69	{7.0}
18	M16	108	{11.0}
22	M20	294	{30.0}

4. Connecting with Other Equipment

⚠ CAUTION



Pay attention to the centering, belt tensioning, pulley alignment, etc. when the gearmotor is connected to the load. In the case of a direct connection, make sure the connection is precise. When using a belt, make sure to adjust the belt tension correctly. Be sure to tighten the bolts for the pulley and couplings before operation. Otherwise, injury and application damage may occur due to the scattering of broken pieces.



Apply a cover, etc. so that rotation parts are not exposed. Otherwise, injury may occur.

Be sure to use the specified key to assemble the connection device (a coupling/sprocket/pulley/gear, etc.) to the reducer shaft with a fit of about H7 class.

4-1. When directly connected

The shaft center of the application and the shaft center of the reducer must be aligned axially.

■ Coupling Example

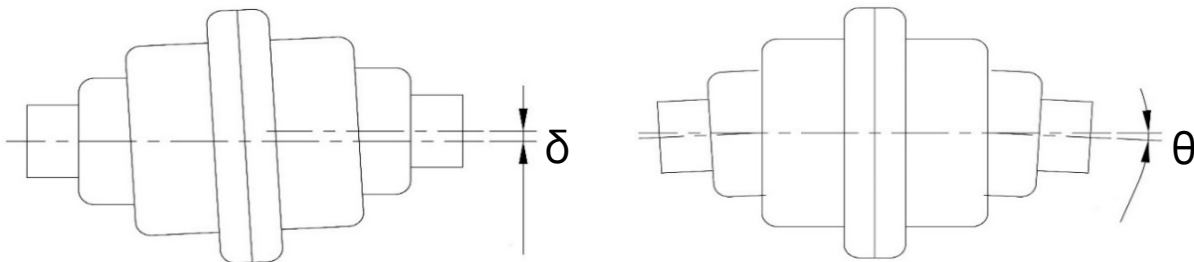

- The displacement amount of δ and θ should be minimized.
- The δ and θ differ according to the type of coupling. Therefore, they should be within the allowable value defined by the manufacturer.

(Reference: In the case of chain coupling, δ should be within 2% of the roller chain pitch and θ should be within 1°)

4-2. Attaching Chains, V-belts, Gears, etc.

- (1) The shaft center of the application and the shaft center of the reducer must be parallel to each other.
- (2) Chain, V-belt tension and gear engagement must be at a right angle to the output shaft.
- (3) V-belt tension : If it is too tight, the bearing may become damaged.
Chain tension : If it is too tight, the bearing may become damaged. High impact forces may also occur if it is too loose, it would result in adverse effects on the reducer and application. The tension of the chain should be correctly adjusted.

■ Correct

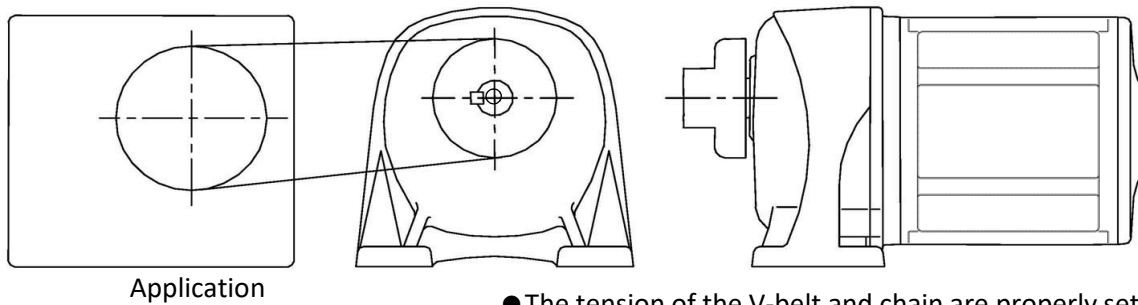

- The tension of the V-belt and chain are properly set.
The pulley and sprocket are properly positioned.

■ Incorrect

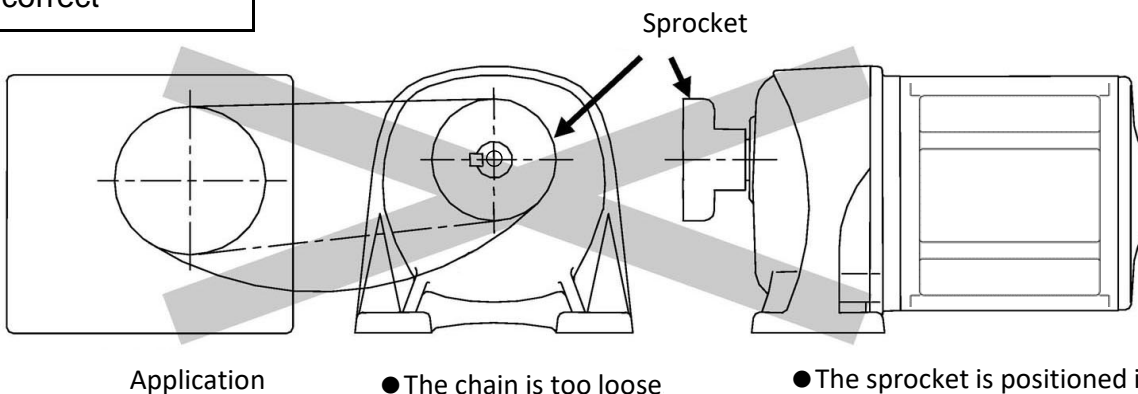

- The chain is too loose
- The sprocket is positioned in the reverse direction causing the load point to move to the shaft edge.

4-3. Installing/Removing the FS/F3S Type Hollow Shaft

■ Installing the hollow shaft of reducer to the drive shaft

- Coat the drive shaft surface and interior surface of the hollow shaft with a lubricant (molybdenum disulfide) suitable to the atmosphere in which they will be used and connect the reducer to the drive shaft.
- When used with uniform loads, a drive shaft tolerance of h7 is recommended. Additionally, when dealing with impact loads or large radial loads, make sure they fit each other tightly. The tolerance of the interior surface of hollow shaft is designed to be H8.
- If the shafts are a tight fit, use a plastic hammer on the end of the hollow shaft to insert it. When doing so, be sure not to hit the casing. If you make a jig like the one in the diagram below, drive shaft insertion will be easier.

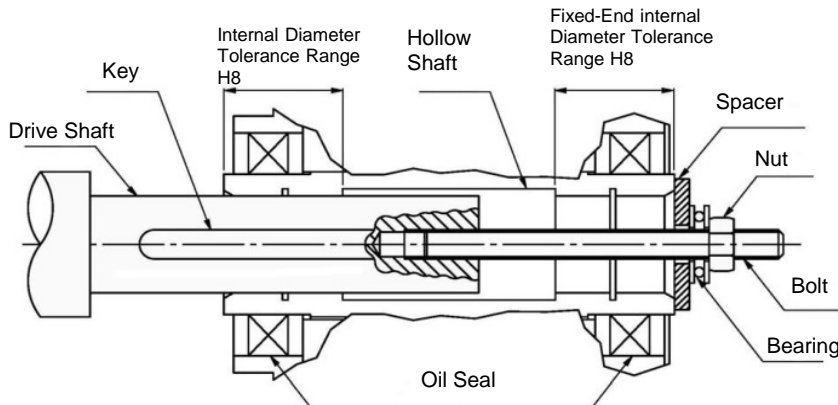

(Tighten the nut to insert the output shaft.)

(Customers need to provide their own spacer, nuts, bolts, keys and shaft bearings.)

- For the length of the turn-stop key for the drive shaft, tolerance range H8 for the internal diameter on the fixed side is recommended.
- It is recommended that axial runout for the shaft be 0.05 mm or less at the shaft end. If major wobbling occurs during operation, it may have a negative effect on the reducer.

■ Connecting the reducer to the drive shaft

① When there are steps on the drive shaft

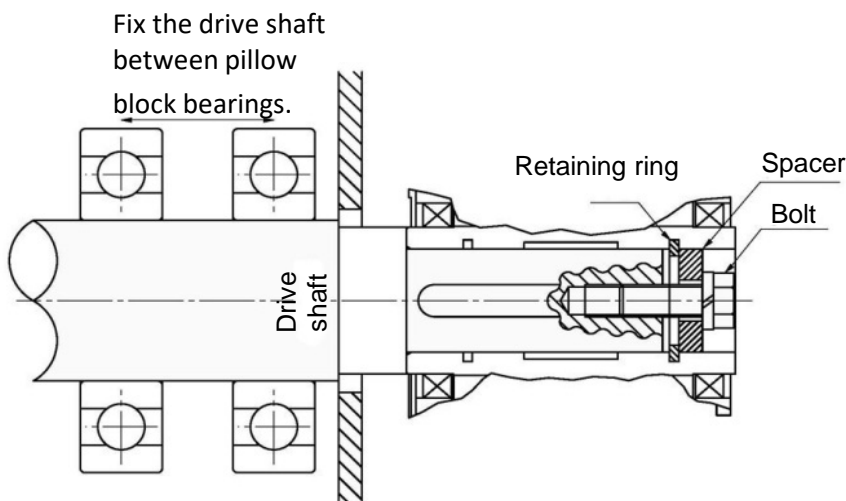

Figure. Attachment Using a Spacer and Retaining Ring
(Customers need to provide their own spacer, bolts, and retaining rings.)

Note) Be careful when tightening the bolt, as tightening it too much can distort the shape of the retaining ring.

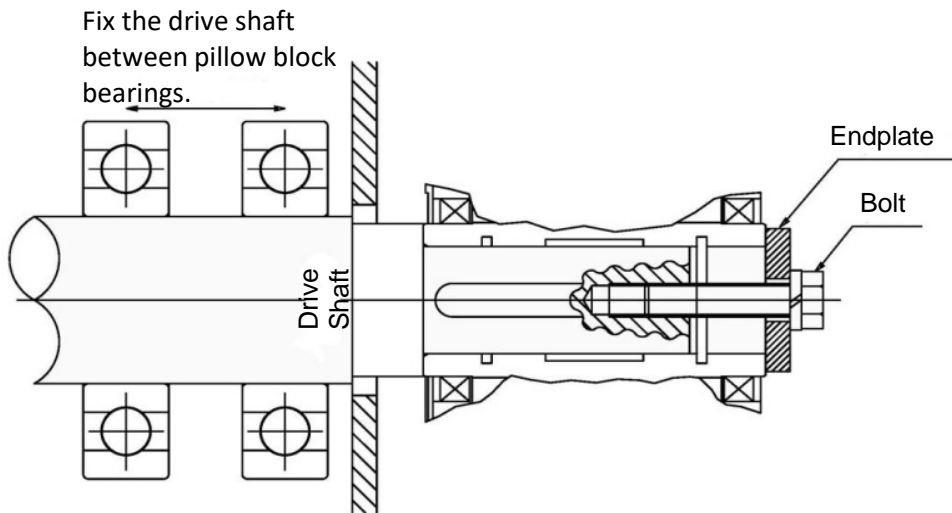

Figure. Attachment Using an Endplate
(Customers need to provide their own endplates and bolts.)

Note) Please understand that for the connection method above, mounting of resin cover for the F Series is not possible due to the bolt interference.
In addition, please apply a protective cover when possible so that there is no injury due to objects getting caught in the output shaft.

② When the drive shaft has no steps

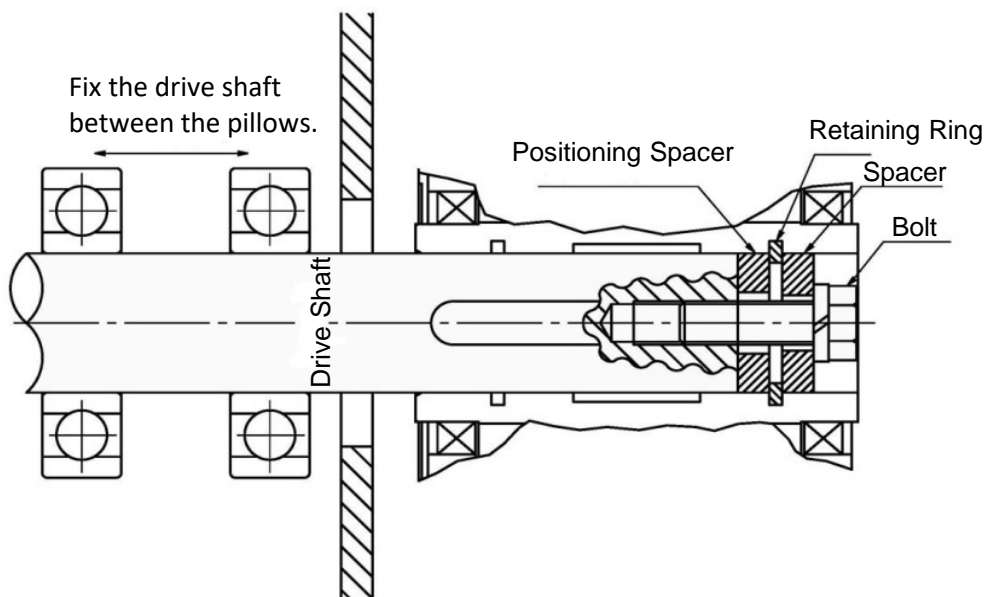

Figure. Attachment Using a Spacer and Retaining Ring
(Customers need to provide their own spacer, positioning spacers, bolts, and retaining rings.)

Note) Make sure there is a gap between the outer diameter of the spacer and the internal diameter of the hollow shaft. If the fit is too tight and the outer diameter of the spacer is inaccurate, axial runout of the drive shaft and hollow shaft can result.

The positioning spacer is used to position the reducer. It is not required if you know the length of the drive shaft in advance. In addition, attaching the positioning spacer allows for smooth removal from the hollow shaft. (Refer to "■ Removal from the hollow shaft" on next page)

Recommended Sizes for the Fixing Elements of the Drive Shaft

When attaching the hollow shaft in general use, refer to the dimensions shown below as a guideline when designing.

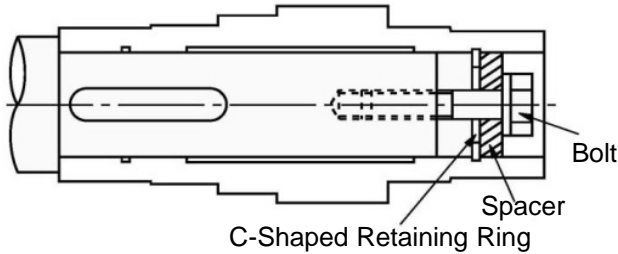

<Recommended sizes for the fixing elements>
(mm)

Hollow shaft hole diameter	Bolt size	Spacer dimensions			C-shaped retaining ring for holes
		Outer diameter	Internal diameter	Width	
φ20	M6	φ19.5	φ7	3	20
φ25	M6	φ24.5	φ7	4	25
φ30	M8	φ29.5	φ9	5	30
φ35	M10	φ34.5	φ11	5	35
φ45	M10	φ44.5	φ11	5	45
φ50	M12	φ49.5	φ13	6	50
φ55	M12	φ54.5	φ13	6	55

Drive Shaft Length

Make sure the driven shaft reaches both ends of L1 (See the figure to the right.) However, take note of how much room is necessary for spacers in the section titled "Removal from the hollow shaft."

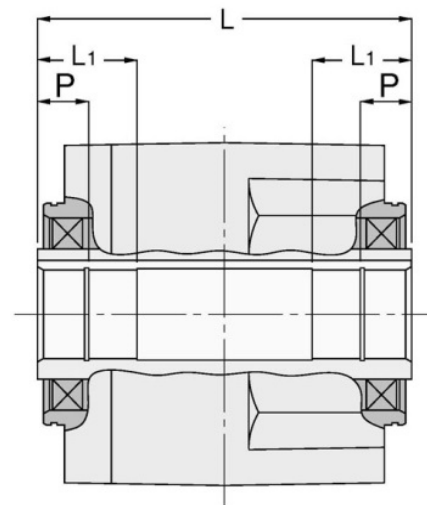

Drive Shaft Key Length

The length of the key should be at least 1.5 times the diameter of the hollow shaft. Additionally, the key should be inserted in such a position that at least half its length is in L1. (See the figure to the right.)

Removal from the Hollow Shaft

Make sure there is enough room at the end of the hollow shaft to use the jig shown below. If you make and use a jig like the one below, drive shaft removal will be easier.

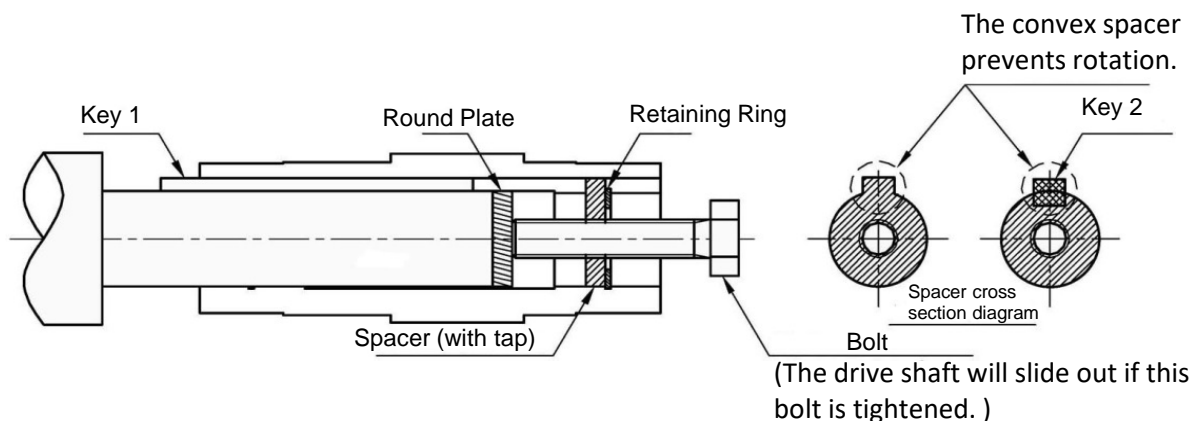

(Customers need to provide their own spacers, round plates, bolts and retaining ring keys.)

4-4. Installing a Flange/Torque Arm

<Advantages and disadvantages of flange and torque arm installation>

	Advantages	Disadvantages
Flange Installation	<ul style="list-style-type: none"> ● Can be installed directly on the application. ● Saves space. 	<ul style="list-style-type: none"> ● Centering with the application is required. ● Requires four(4) tapped holes for mounting to the application.
Torque Arm Installation	<ul style="list-style-type: none"> ● Makes centering with the application easy. ● Fastening to the application only requires one detent. 	<ul style="list-style-type: none"> ● Requires a torque arm. ● Requires space for installing a torque arm. ● Not suitable for position control.

■ Installing a flange

When the hollow bore is installed directly to the flange of an application, it can cause motor burn-out or bearing damage if it is off-center, so be sure to center it properly.

There is an installation guide, as shown in the diagram to the right. The dimension tolerance for ΦA on the installation guide is h7 in the case of F3. The installation bolts are installed as shown in the diagram to the right. Four bolts should be used.

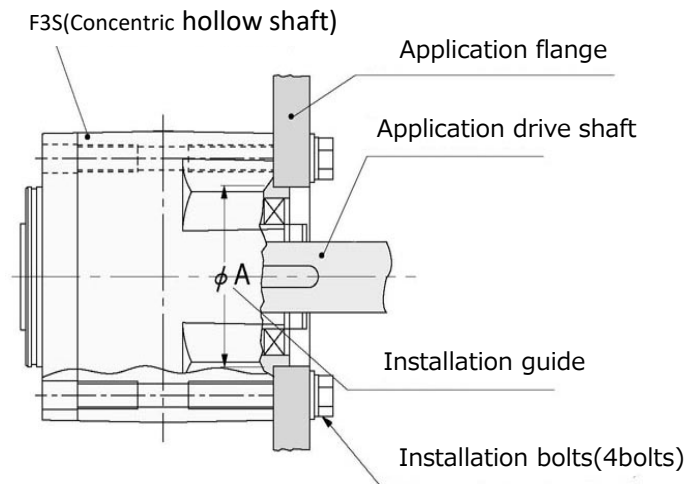

■ Fastening the Reducer and Torque Arm

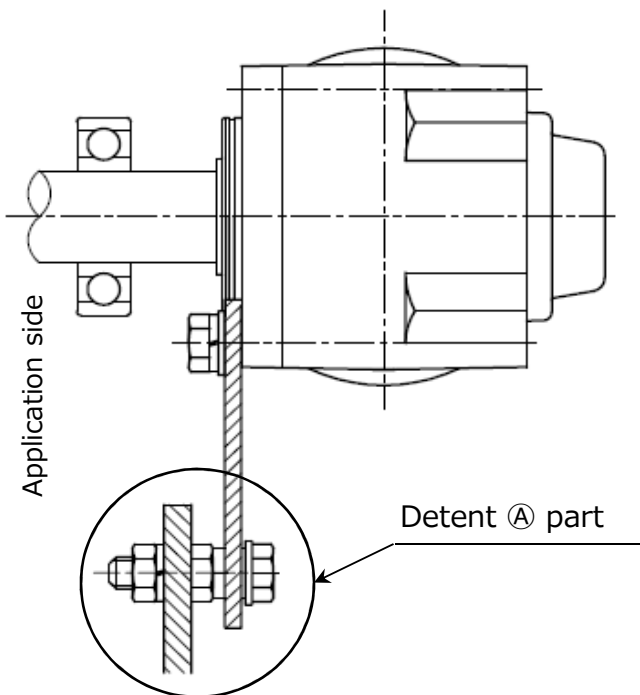

- Install the torque arm detent to the application side.
- Because the torque arm sustains a reactive force from rotation, consideration needs to be given to impact loads particularly during startup and braking. Bolts and plates that are sufficiently strong must be used. It is best to use our optional torque arm.
- To install the torque arm and reducer, fasten them using spring washers and flat washers with the installation bolts.

<Bolt Size and Tightening Torque>

(Reference value)

Bolt size	Tightening torque N·m {kgf·m}
M8	13 { 1.3 }
M10	25 { 2.6 }
M12	44 { 4.5 }
M14	69 { 7.0 }
M16	108 { 11 }

● How to install the Torque Arm Detent (A) part

① For normal/reverse rotation operation and unidirectional operation (intermittently)

Fasten the torque arm detent so there is no looseness or wobble.

When doing this, center the detent hole with that of the application to make sure that no radial load (suspension load) is applied against the driven shaft and hollow shaft of the reducer. (Refer to the diagram below.)

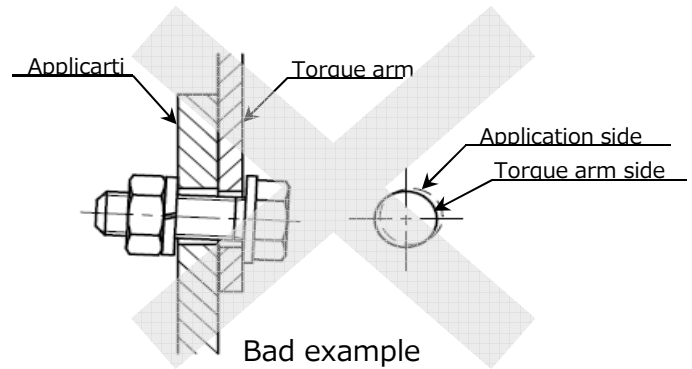
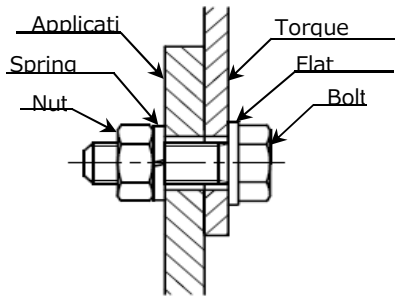

Unnecessary force applied to the driven shaft and hollow shaft can result in defects.

Note) If mounting has a looseness, impact may be applied to the torque arm with each startup and defects such as loosen bolts may occur.

If mounting without looseness are not allowed for some reason, rubber bush or other cushion materials shall be used between the torque arm and the bolt as a protective measure. Bolts with sufficient strength shall be used. (Refer to the right diagram.)

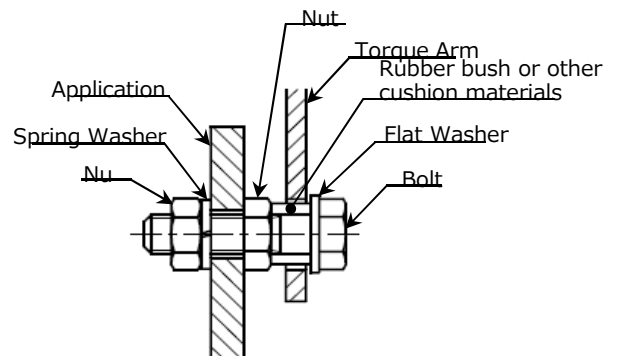

② Unidirectional operation (consecutive)

For unidirectional operation (consecutive) which has no frequent start-up torque applied, the torque arm can be used without a detent.

However, it is still necessary to fasten the driven shaft to the hollow shaft.

(Refer to "4-3. Installing/Removing FS/F3S Type Hollow Shaft".)

In this case, it is necessary to provide sufficient clearance for looseness in both radial and thrust directions for alignment between the application and detent.

(Refer to the diagram below.)

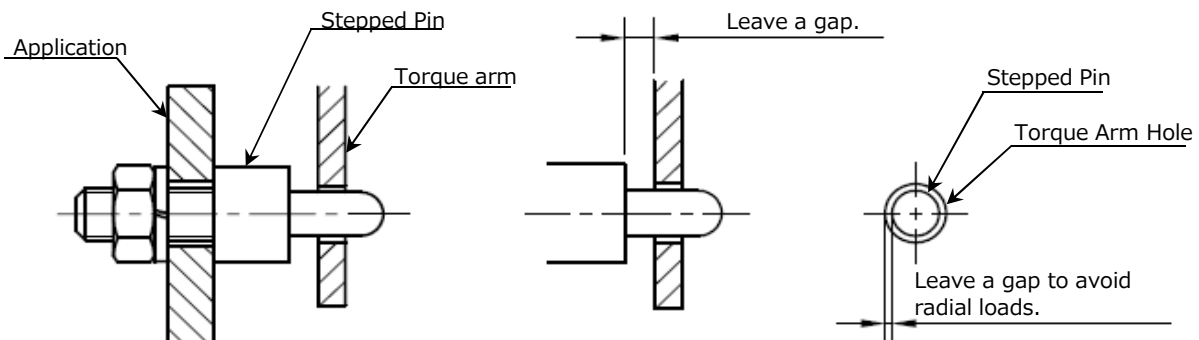

Example of Stepped Pin Usage

5. Rotational Direction

⚠ CAUTION



Check the direction of rotation before the gearmotor is connected to the application. A difference in rotational direction may cause injury and/or damage to the application.

The relationship between the input shaft (motor) and the output shaft rotational direction of this product are as follows.
The following rotational direction is the rotation when "6. Wiring." is connected as normal rotation.

■ For G3 Series

0.1kW 1/5 ~ 1/50 and 1/300 ~ 1/1200
0.2~2.2kW 1/5 ~ 1/30 and 1/300 ~ 1/1200

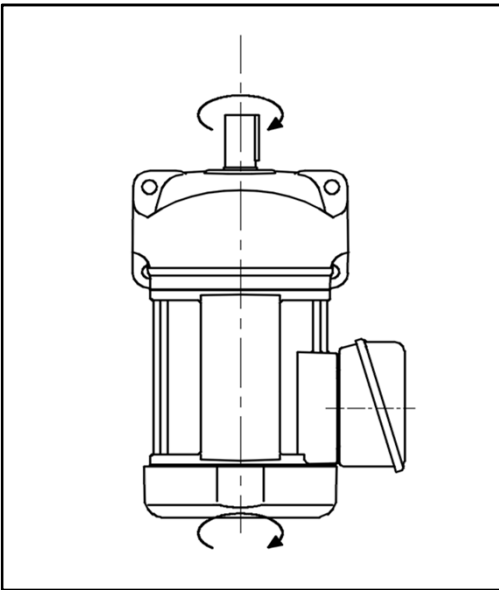

0.1kW 1/60 ~ 1/200
0.2~2.2kW 1/40 ~ 1/200

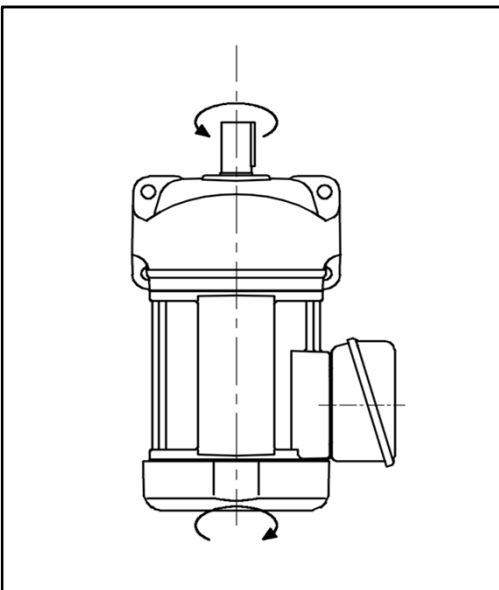

■ For H2 Series

0.1·0.2kW 1/5 ~ 1/60 and 1/600 ~ 1/1500
 0.4~0.75kW 1/5 ~ 1/60 and 1/300 ~ 1/1500
 1.5·2.2kW 1/5 ~ 1/30

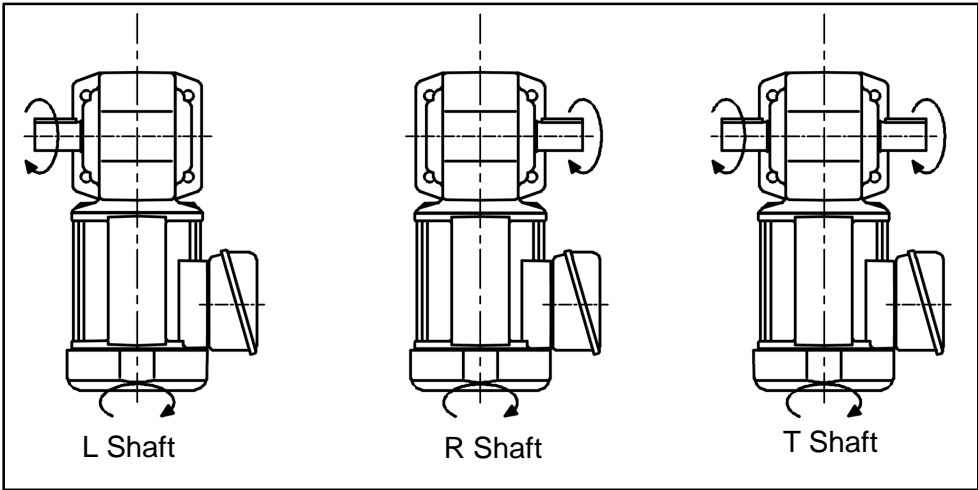

0.1·0.2kW 1/80 ~ 1/450
 0.4~0.75kW 1/80 ~ 1/240
 1.5·2.2kW 1/40 ~ 1/240

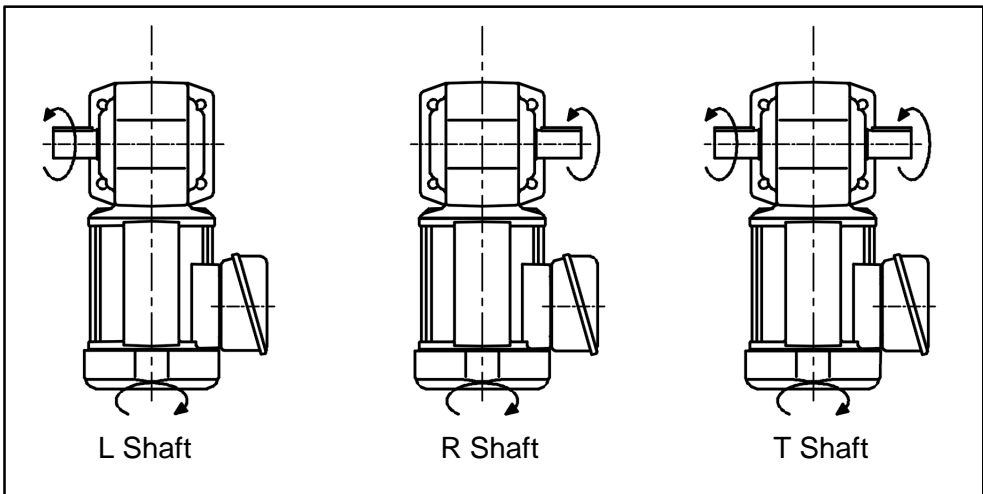

■ For F Series

0.1~0.75kW 1/5 ~ 1/60 and 1/300 ~ 1/1500
1.5~2.2kW 1/5 ~ 1/30

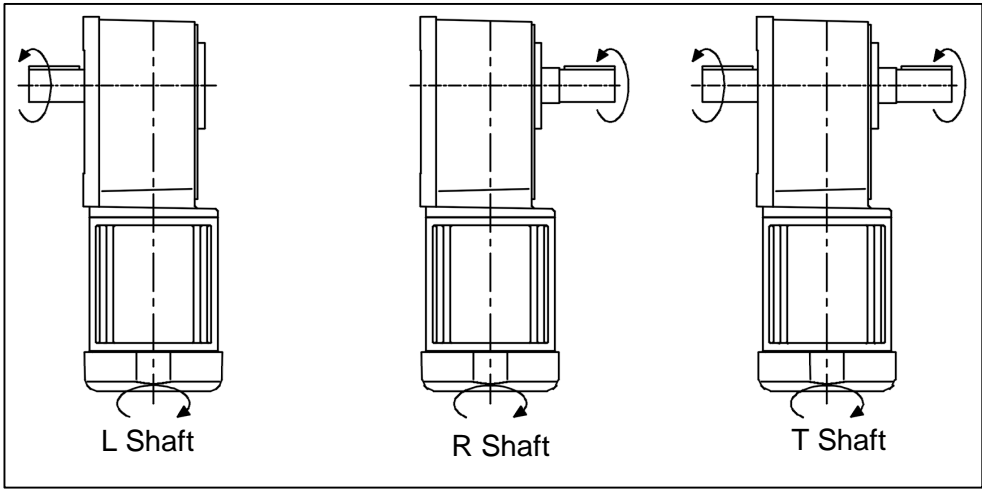

0.1~0.75kW 1/80 ~ 1/240
1.5~2.2kW 1/40 ~ 1/240

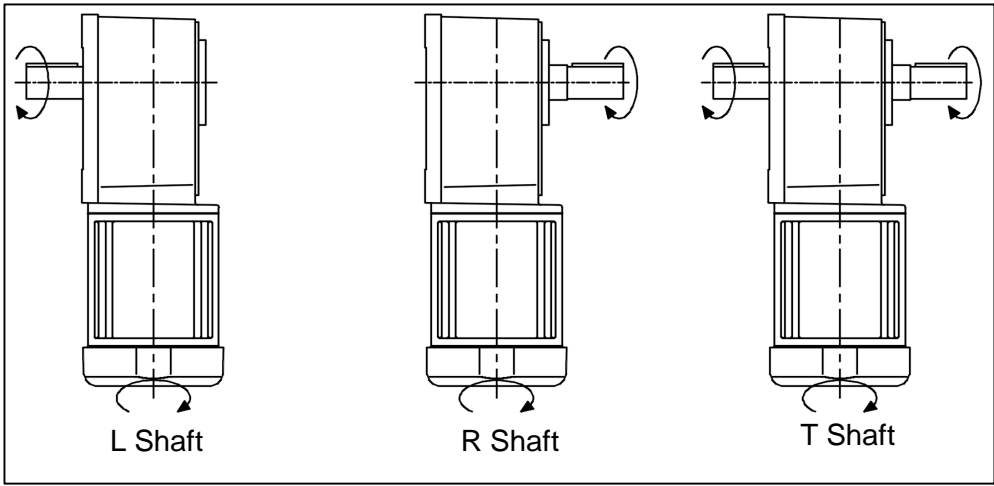

■ For F3 Series

0.1~2.2kW 1/5 ~ 1/60

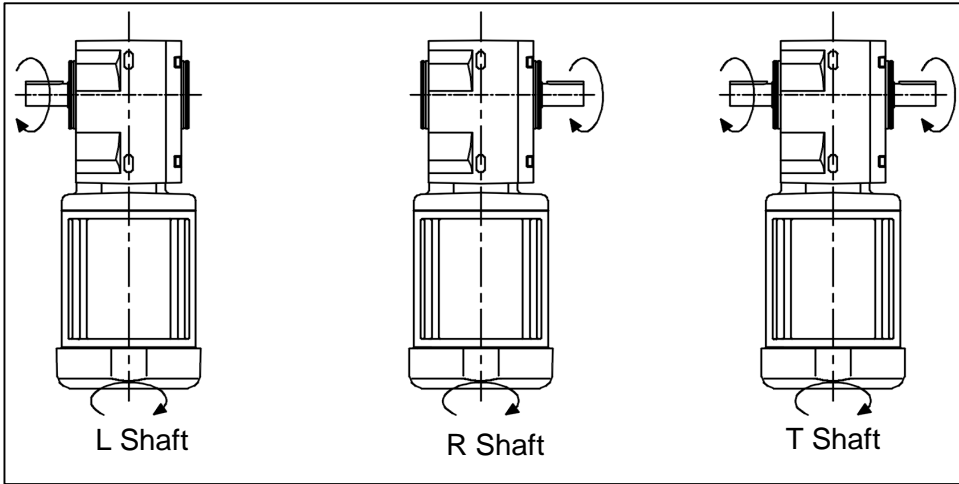



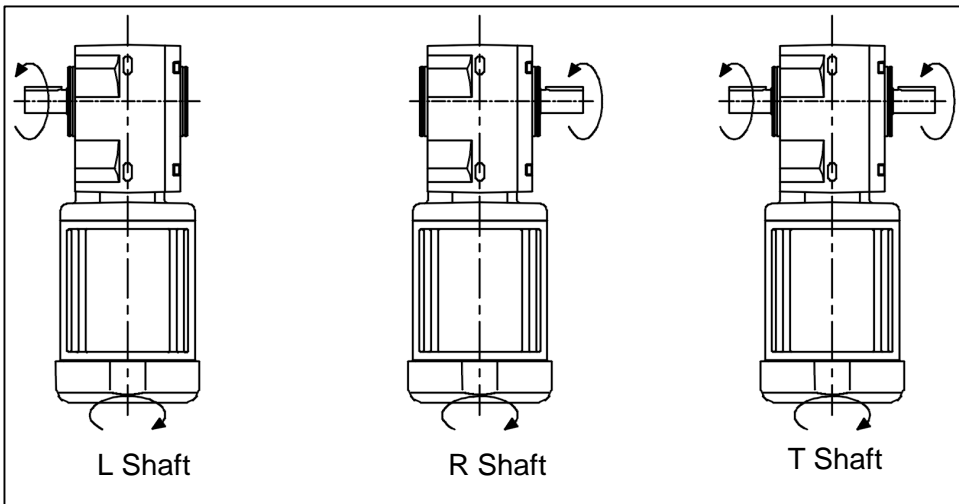











0.1~1.5kW 1/80 ~ 1/240
2.2kW 1/80 ~ 1/120



















6.Wiring

DANGER

		Connect the power cable according to the instruction manual. Otherwise, an electric shock and/or fire may occur.
		Do not forcibly bend, pull or pinch the power cable and motor lead wires. Otherwise, an electric shock may occur.
		Be sure to ground the grounding terminal. Otherwise, an electric shock may occur.
		Be sure to use the supply voltage described on the nameplate. Otherwise, motor burn damage and fire may occur.
		Be sure to supply proper input voltage and perform proper connection to the motor and the inverter. Connection to the wrong terminal may cause application failure, electric shock, and fire.
		Do not supply commercial power directly. Otherwise, fire may occur.
		Do not perform wiring as voltage is generated at the motor terminals, while the motor is running, even when the power has been turned off. Otherwise, an electric shock may occur.

CAUTION

		Do not touch the terminals when measuring the insulation resistance. Otherwise, an electric shock may occur.
		Perform wiring according to the applicable safety standards and regulations. Otherwise, burn damage, an electric shock, fire and/or injury may occur.
		The motor has no standard protective device. It is recommended that a protective device (such as a power leakage insulator, etc.) other than the overload protective device is installed. Otherwise, damage, an electric shock, fire and/or injury may occur.
		When running the gearmotor off the application, please remove the temporarily attached key from the output shaft. Not doing so may result in injury.
		Check the direction of rotation before the gearmotor is connected to the application. Running an application in the wrong direction may cause injury and/or damage to the application.
		The voltage drop from the wiring should be 2% or lower. If the wiring distance is too long, the voltage drop will be larger and the gearmotor may not start.
		When reversing the rotation, be sure to stop the motor completely before starting the reverse rotation. Otherwise, the application may be damaged.
		For a gearmotor with brake, do not energize the brake coil continuously while the motor is stationary. Otherwise, coil burn damage and/or fire may occur due to reduced ventilation.

6-1. Gearmotor Wiring <Common Items>

■ Precautions for Terminal Box/Terminal Block

- Use the nuts and short circuit plate included for terminal block connection.
- The tightening torque of the nut mounted on the terminal block is 1.2 to 1.5 N·m (12 to 15 kgf·cm).
- The tightening torque for the ground terminal is 1.2 to 1.5 N·m (12 to 15kgf·cm).
- Be sure to assemble and fasten the terminal box lid with fixing screws after wiring.
- The tightening torque for the lid on the T type terminal box is 0.4 to 0.8 N·m (4 to 8kgf·cm).
- Refer to “■How to Change Terminal Box Mounting Direction” if the direction of the terminal box cable outlet must be changed.
- Please contact your nearest service office if the rubber gasket of the terminal box is cut or damaged. An electric shock and apparatus damage may occur if the motor is used with a damaged gasket. (Refer to the final page for details.)
- A rubber grommet with a membrane is attached to the opening part of the T type terminal box to protect the cable or the lead wire. Cut open the surface when performing wire connection.
- A rubber sheet for insulation and water-proof is attached to the lid of E type terminal box. Please do not remove the rubber sheet. Otherwise, a short circuit and electric shock may occur. If by any chance the rubber sheet comes off, be sure to put it back on the lid so that the rubber sheet fits properly on the lid.
- The tightening torque for the lid on the E type terminal box is 1.2 to 1.5 N·m (12 to 15kgf·cm).

■ How to Change The Terminal Box Mounting Direction

Change the terminal box mounting direction as follows if the direction of the terminal box outlet hole must be changed.

※ Note that malfunctions due to this procedure being performed incorrectly is not covered by our warranty.

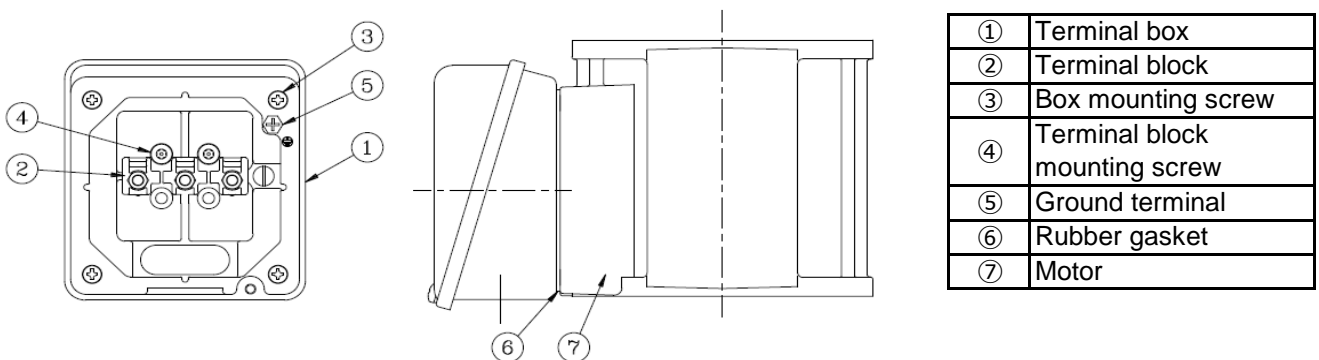

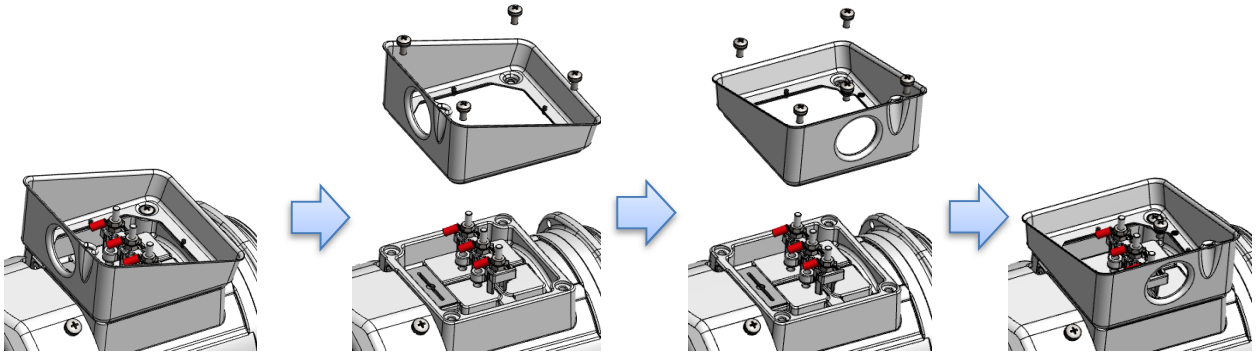

- (1) Loosen the four Box mounting screws ③ and remove the terminal box.
 - ※ The Rubber gasket ⑥ is attached to the bottom part of the terminal box.
Be careful not to remove the rubber gasket.
- (2) Mount the terminal box in your desired direction and tighten the mounting screws.
The tightening torque for the mounting screws is 1.2 to 1.5 N·m (10.6 to 13.3 lbf·in).
 - ※ Mount the box carefully so that the lead wires for the motor and brake are not pinched between the motor and the box.

Note) Do not change the mounting direction of the Terminal block ②.
Defects caused by a customer changing the terminal block mounting direction are not covered by the warranty.

■ Precautions when Wiring a Gearmotor with a Brake

- The brake may cause malfunction by the fluctuation in voltage. It is necessary to let the brake wires bypass the driver.
- The brake voltage for 200V class brake is 90V DC.
The color of brake lead wires for 200V class brake are blue.
- Connect a surge suppressor (optional accessory) between the contacts for a DC Switching connection.
Please contact your local service office for details on the surge suppressor. (Optional Accessory).
(The varistor voltage is 423V to 517V.)
- Use switches of 110V DC <220V DC> with a contact point rating of 13 DC to block the inductive load of the DC coil when using DC Switching.
Please contact your local service office for further details.
※ "A Contact point rating of 13 DC" is a classification under JIS C 8201-5-1
(Low voltage switching device and control device) for coil load applications.
- Note that the rectifier has a diode built in, which may become unusable if a short circuit occurs due to improper connections, etc.
- The input voltage to the rectifier must be within the range specified below. Please be aware that repeated operation beyond this range may cause a malfunction.
200V Class(A200-D90-UL) : AC200V~230V±10%
- Refer to " ■ Brake ON/OFF timing " for operation command and the timing for the Brake ON/OFF.
(Limited to case of using inverter which our company specify)

6-2. Gearmotor Wiring

Refer to the relevant motor wiring diagram in the connection table below to perform wiring for your gearmotor.

For the motor's direction of rotation in the connections below, "Forward" is defined as clockwise rotation seen from the motor end.

The rotational direction of the output shaft depends on the reduction ratio of the gearhead.

Check the reduction ratio before connection.

Securely ground the ground terminal to avoid risks of an electric shock.

■ Wiring Table

※The figure number in () is an optional specification for the built-in rectifier.

Supply Voltage		Motor		Wiring Diagram Number		
Model Code	Voltage (V)	No. of lead wires	Terminal Box	without Brake	with Brake	
					AC Switching (A)	DC Switching
N	200 ~ 230	3	w/ Box	Fig.-①	Fig.-② (Fig.-AA)	Fig.-③

■ Wiring List

No. of lead wires	Terminal Box	Brake Wiring	Wiring Diagram	
3	w/Box	n/a	Fig.-①	
3	w/Box	w/Brake	Fig.-② AC Switching(A)	Fig.-③ DC Switching

※B1·B2 terminals are located in the terminal box.

※B1·B2 terminals are located in the terminal box.

MC : Magnetic contactor

: Surge Suppressor(option)

No. of lead wires	Terminal Box	Brake Wiring	Wiring Diagram
3	w/Box	w/Brake	<p>Fig.-AA AC Switching(A) ※with built-in rectifier option</p> <p>※Terminal "AC" located in the terminal box. ※The rectifier type is "A200-D90-UL".</p>

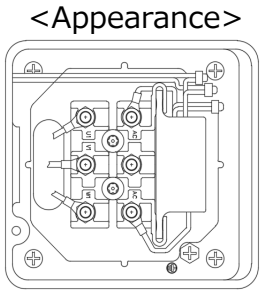

MC : Magnetic contactor

■ Brake ON/OFF timing

(Limited to case of using inverter which our company specify)



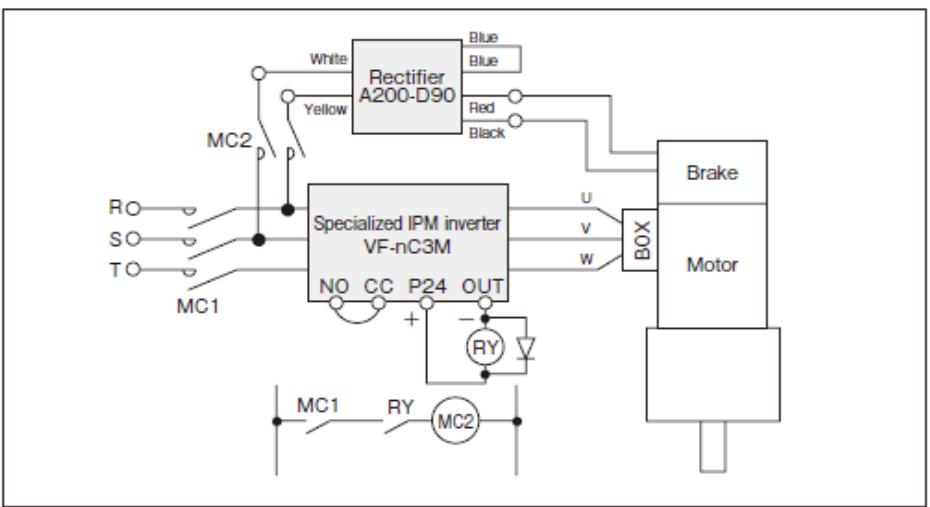





Example of circuit composition for brake ON/OFF (In case of AC switching (A))











Note) The function of output terminal OUT utilizes the " Brake open signal"
 (Function No. 68 [Positive logic], 69 [Negative logic]).
 (Function No. 68 has already been assigned when shipped from the factory.)

7.Operation • Specifications

DANGER

		Do not operate the motor while the terminal box cover is removed. Mount the terminal box cover in the original position after work. Otherwise, an electric shock may occur.
		Do not approach or touch rotating bodies (output shafts, etc.) while the product is running. Otherwise, entanglement and injury may occur.
		Be sure to turn off the power switch when a power failure occurs. Otherwise, sudden power recovery may cause injury and application damage.
		Do not perform wiring as voltage is generated at the motor terminals, while the motor is running, even when the power has been turned off. Otherwise, an electric shock may occur.

CAUTION

		Do not touch the gearmotor which may be hot when energized or for a while after the power is shut off. If touched it may result in burns.
		Immediately stop operation of the gearmotor if there is any abnormality. Otherwise, an electric shock, injury and/or fire may occur.
		Do not use the motor with loads that exceed the ratings. Otherwise, injury and application damage may occur.
		Do not remove the fan for gearmotors without a brake and gearmotor with clutch and brake whose capacity is 1.5 kW or more. Once removed, it will be impossible to reinstall properly. It will no longer be secure on the motor shaft and may come off. If it is removed, please contact our nearest service office.

■ Pre-Operation Checks

- Is the wiring correctly performed?
- Is the capacity of the fuse and thermal relay appropriate?
- Is the product correctly installed?
- Is the ground connection properly done?

■ Trial Operation Checks

- Switch the motor on for 1 to 2 seconds under no load to check the rotational direction before installing to the application.
If the direction is wrong, refer to “6. Wiring.” and change the wiring.
- Connect to the application and operate at not load.
If there is no abnormality, gradually increase the load up to full load.

■ Routine Operation Checks

- Refer to the details of the daily inspection and check the state of operation .
Immediately stop the operation if there is any abnormality.
Otherwise, application damage, injury, fire, an electric shock and burn may occur.
- Refer to “10. Troubleshooting,” etc. for the diagnosis when an abnormality occurs and do not operate the motor until the causes of error are found and corrective actions are taken.

■ Motor Specifications

Motor Type		IPM Motor (Embedded Magnet Motor)					
Rated Output[kW]		0.1	0.2	0.4	0.75	1.5	2.2
Number of Motor Poles ※1		4 pole			6 pole		
Instant Max. Torque (compared to rated)		150%					
Rated Current[A] ※2		0.45	0.86	1.74	3.37	6.13	8.2
Min. Rotational Speed[r/min] ※3		0					
Rated Rotational Speed[r/min]		1800(60Hz)			1800(90Hz)		
Max. Rotational Speed[r/min] ※4		2500(83.3Hz)			2500(125Hz)		
Constant torque speed control range[r/min]		180~1800(1 : 10)			120~1800(1 : 15)		
Start/Stop Frequency		30 times/min					
Insulation Class		Class F(155°C)					
Protection Method	Standard w/o Brake	TENV(IP44)				TEFC (IP44)	
	Standard w/ Brake						
	Water-resistant w/o Brake	TENV(IP65)				TEFC(IP65)	
	Water-resistant w/ Brake						

※1 Number of motor poles differ depending on the motor power.

Note that the relationship between motor speed and frequency setting is shown in the following formula.

$$\text{Rotational Speed(r/min)} = \frac{120 \times \text{Frequency setting}}{\text{Number of motor poles}}$$

※2 Rated current is a reference value of the motor without a gearhead.

※3 Rotational loss may occur when operating below 100r/min.

※4 Please note for the output torque as 1800~2500r/min is a constant output characteristics.

8. Standards

■ Gearmotor Safety Standards

Country	U.S.A.	Canada	Europe(EU)	China
No. of phases	3-phase	3-phase	3-phase	3-phase
Standards	UL	CSA	EN	GB
Standards No.	UL1004-1	CSA C22.2 No.100	EN60034-1 EN60034-5	GB/T12350-2009
UL File No.	NDMM2. E327462	NDMM8. E327462		

■ IPM Motor Efficiency Regulation Support Status

Country Name		China
Law		永磁同步电动机能效限定值及能效等级
Standards		GB 30253-2013
Support Details	Capacity Range	0.75kW~2.2kW
	No. of Poles	6
	Efficiency Class	Class 1

- Support details are applicable to gearmotor efficiency regulations.
- The contents above are subject to change without a prior notification in accordance with change of standards, etc.

■ By Country(Area)

1. U.S.A.

● Safety Standards

<Target Standards and UL File>

No. of Phases	Target Standards	UL File No.	Motor Power	Support Details [power/standards]
				NV
3-phase	UL1004-1 (Standard for Rotating Electrical Machines – General Requirements)	NDMM2. E327462	0.1kW ~ 2.2kW	

2. Canada

● Safety Standards

<Target Standards and UL File>

No. of Phases	Target Standards	UL File No.	Motor Power	Support Details [power/standards]	
				NV	
3-phase	C22.2 No.100 (Motors and Gearmotors)	NDMM8. E327462	0.1kW ~ 2.2kW		

3. Europe

● Safety Standards

No. of Phases	EU Directive	Target Standards	Motor Power	Support Details [power/standards]	
				NV	
3-phase	Low Voltage Directive 2014/35/EU	EN60034-1 : Rotating Electrical Machine - Part 1: Rating and Characteristics EN60034-5 : Rotating Electrical Machine - Part 5: Classification of Protection Ratings with Integrated Type Design for Rotating Electrical Machine (IP Code)	0.1kW ~ 2.2kW		

4. China















● Safety Standards











No. of Phases	Target Standards	Capacity	Support Details [power/standards]					
			NN	WN	KN	CN	AN	EN
3-phase	GB/T12350-2009 Small Power Motor Safety Requirements	0.1kW to 0.75kW						

● High-efficiency Regulation

No. of Phases	Target Standards	Capacity	Support Details [power/standards]	
			NV	
3-phase	GB 30253-2013 Minimum allowable values of energy efficiency and energy efficiency grades for permanent magnet synchronous motors	0.75kW ~ 2.2kW		

9. Inspection and Adjustments

 DANGER	
 	Do not touch rotating bodies (output shafts, etc.) when the gearmotor is being maintained/inspected while it is running. Otherwise, entanglement and injury accidents may occur.
 	Do not remove the internal inspection cover while the gearmotor is running. Otherwise, high-temperature lubricant may disperse causing burns.
 	Be sure to stop rotation of the application when checking the tooth surface condition of the stopped gear. Otherwise, entanglement to the gear engagement part and injury may occur.
 	Be sure to stop rotation of the application and wait for that inside of the product to sufficiently cool down to inspect the inside of the product. Furthermore, please allocate a third party to constantly check for safety while the inspection is conducted by the inspector. In addition, the inspector shall confirm that the inside of the product is sufficiently lubricated, and that all safety measures are properly implemented. Otherwise, accidents with injury may occur.
 	Do not operate the product while the safety cover, etc. is removed during inspection. Otherwise, entanglement and injury may occur.
 	Do not operate the product while the brake is manually released via the manual release lever. Otherwise, an out-of-control accident may occur.
 	If the motor is used for lifting, do not release the brake while a load is lifted. Otherwise, a drop accident may occur.

 CAUTION	
 	Do not touch the terminal when the insulation resistance is measured. Otherwise, an electric shock may occur.
 	Do not touch the gearmotor surface with your bare hand. The surface may become very hot, which may cause burns
 	Execute a diagnosis based on the instruction manual in case of abnormalities. Never operate a motor until you properly identify and resolve any abnormalities.
 	Be sure that repair/disassembly/assembly is done by an authorized expert. Otherwise, an electric shock, injury, fire, etc. may occur.
 	Do not disassemble as strong magnet are used. Otherwise, injury and application failure may occur.

Note) If you need parts replaced (grease / oil seal / O-ring, etc) for maintenance/inspection purposes, please contact your nearest service office (described on the final page of the instruction manual). Please note that defects caused by the replacement of parts by a customer are not covered by our warranty.

■ Grease/Oil Seal/O-Ring

- NISSEI CORPORATION utilizes grease for lubrication for G3, H2, F and F3 Series, and specified amount of grease pre-sealed in each unit before shipping so that the motors can be used without further lubrication.
- Although replacement and replenishment are not required in most cases, if necessary, you may replace the grease at around the 10,000 hour mark to potentially increase the life-span of your motor. However, please note that grease replacement must be performed at our factory and is considered a repair order.
- Though the Oil seals and O-rings should prevent grease leakage from the motor, we highly recommend that you use protection such as oil-pans to prevent potential accidents.
(Leakage tends to occur at the end of a motor's life, or in instances of break-downs.)
- Oil seals may need to be replaced before the 10,000 hour mark depending on the environment and usage. Please note that oil seals must be replaced at our factory and are considered repair orders.

■ Daily Inspection

To be performed every 2 to 3 days.

Inspection item	Method	Inspection details
Load Current	Ammeter	Within the rated current described on the nameplate
Noise	Auditory Observation	No abnormal sound (Rattling sound, periodic sound)
		*Apply a listening rod to the bearing part to check abnormal sound.
Vibration	By touch	No abnormal vibration of the gear case and motor frame
Surface Temperature	Thermometer	No rapid increase or decrease of normal temperature.
Grease Leakage	Visual Observation	No leakage from the joint part of the case, oil seal, bracket, etc.

■ Regular Inspection

Based on 8 hours/day operation.

Inspection item	Inspection frequency	Inspection details
Mounting Bolt	Every 6 months	Check the looseness with a spanner. Tighten it if it is loose.
Chain and V-belt	Every 6 months	Check the tension. Adjust if too loose or too tight.
Motor Insulation Resistance	Every 6 months	Measure with an insulation resistance tester. Resistance must be 1 MΩ or higher under 500V.
Gap Amount (Brake)	Annually or every 1 to 1.5 million times of brake usage	Check whether it is less than or equal to the limitation gap range. For inspection and adjustment methods, refer to the adjustment method in the next page.

※ Refer to “10. Troubleshooting” and execute measures/treatments if errors are recognized with the inspection.

■ Brake Specifications

Standard Type (Brake Type : B2, J2)

Power [kW]	Brake Supply AC Voltage[V]	Brake Supply DC Voltage[V]	Braking Torque [N·m]	Gap[mm]			Recommended tightening torque[N·m]	Screw size
				Initial	Limitation	Adjustable		
0.1	200	90	1.0	0.05~0.20	0.4	0.3	2.1~2.3	M4
0.2			1.96	0.05~0.20	0.4	0.3	2.1~2.3	M4
0.4			3.92	0.05~0.25	0.4	0.35	2.1~2.3	M4
0.75			7.35	0.05~0.25	0.45	0.4	2.1~2.3	M4
1.5			14.7	0.05~0.25	0.55	0.5	6.9~7.6	M6
2.2			21.6	0.05~0.25	0.55	0.5	6.9~7.6	M6

Water-resistant Type IP65 (Brake Type : V2)

Power [kW]	Brake Supply AC Voltage[V]	Brake Supply DC Voltage[V]	Braking Torque [N·m]	Gap[mm]			Recommended tightening torque[N·m]	Screw size
				Initial	Limitation	Adjustable		
0.1	200	90	1.0	0.05~0.15	0.45	0.4	2.1~2.3	M4
0.2			1.96	0.05~0.15	0.45	0.4	2.1~2.3	M4
0.4			3.92	0.05~0.15	0.45	0.4	2.1~2.3	M4
0.75			7.35	0.05~0.15	0.5	0.4	2.1~2.3	M4

- Due to the structure of the brake, the lining may make an abrasive noise during motor operation, however, this does not affect the performance of the brake.

■ Brake Structure

Standard Type (Brake Type : B2, J2)

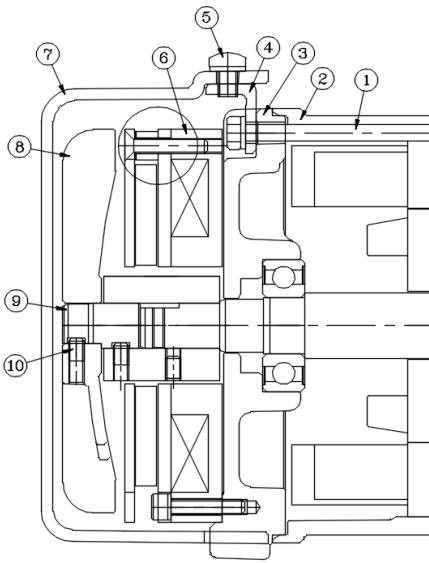

①	Through bolt
②	Motor frame
③	Bracket
④	Stay
⑤	Fan cover fixing screw
⑥	Brake
⑦	Fan cover
⑧	Fan
⑨	Extended Shaft
⑩	Fan fixing screw
⑪	Magnet ASSY
⑫	Collar
⑬	Shim
⑭	Plate screw
⑮	Plate
⑯	Disk
⑰	Armature
⑱	Gap

※0.1kW to 0.75kW have no fans as they are Totally Enclosed Non-ventilated type.

Water-resistant Type IP65 (Brake Type : V2)

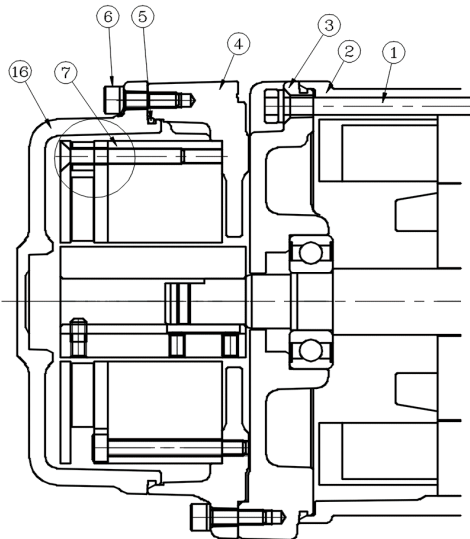

①	Through bolt
②	Motor frame
③	Bracket
④	Spacer
⑤	O-Ring
⑥	Cover fixing bolt
⑦	Brake
⑧	Magnet ASSY
⑨	Collar
⑩	Shim
⑪	Plate screw
⑫	Plate
⑬	Disk
⑭	Armature
⑮	Gap
⑯	Brake cover

■ How to Inspect Brake Gap

- (1) Loosen the ⑤ Fan cover fixing screw and remove the ⑦ Fan cover.
For water-resistant models, loosen the ⑥ Cover fixing bolt and remove the ⑯ Brake cover.
- (2) Check that the ⑱ Gap between the ⑪ Magnet ASSY and the ⑰ Armature is less than or equal to the limitation gap with a clearance gauge, etc.
For Water-resistant types, check that the ⑮ Gap between the ⑧ Magnet ASSY and the ⑭ Armature is less than or equal to the limitation gap with a clearance gauge, etc.
Note) Be sure to turn off the power before the inspection.

■ How to Adjust the Brake Gap

If the disk is worn out after long term usage and the ⑱ Gap between the ⑪ Magnet ASSY and the ⑰ Armature exceeds the gap limitation value described in the brake specifications, malfunctions of the brake may occur. Please Adjust the brake gap as follows.

Even if the gap limitation is not exceeded, the brake gap can be adjusted if the value is greater than or equal to the adjustable gap.

The brake gap adjustment can only be done once.

Note) Do not adjust the gap if the gap is less than the adjustable gap. Otherwise it may cause brake malfunction.

<Gap adjustment procedure>

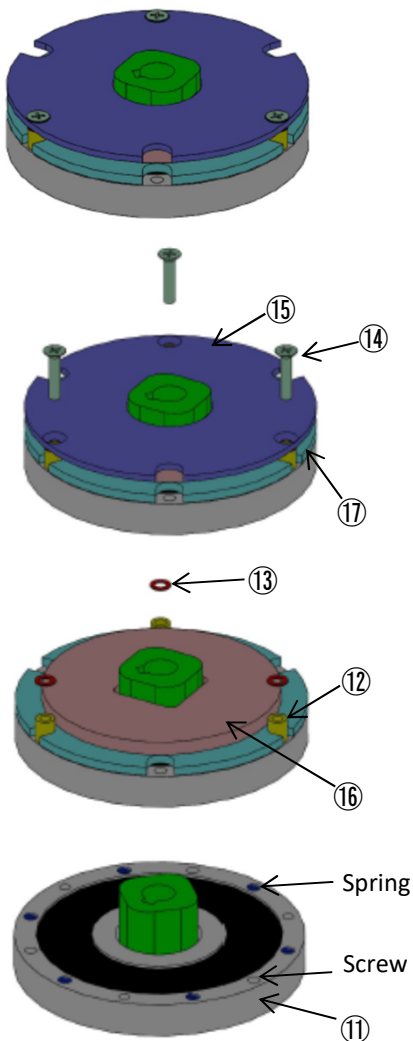

• For a standard type brake

- (1) Loosen the ⑤ Fan cover fixing screw and remove the ⑦ Fan cover.
- (2) Check that the brake gap is greater than or equal to the adjustable gap of 「**■ Brake Specifications**」 under no energization state.
 - ※ Loosen the ⑩ Fan fixing screw and remove the ⑧ Fan if there is one. 0.1kW to 0.75kW have no fans.

• For a water-resistant type brake

- (1) Loosen the ⑥ Cover fixing bolt and remove the ⑰ Brake cover.
- (2) Check that the brake gap is greater than or equal to the adjustable gap of 「**■ Brake Specifications**」 under non-energized state.

• For both brake types

- (3) Remove any wear debris with an air gun.
 - ※ The gap is the space between the ⑪ Magnet ASSY and the ⑰ Armature under no power.
- (4) Remove the ⑭ Plate screw.
- (5) Clean attachments on the screw part.
 - ※ If the screw has a scratch, etc. , please replace it with a new one.
- (6) Remove the ⑮ Plate.
 - ※ Pay attention so that the friction surfaces of the parts are not made dirty.
 - ※ Check that the friction surfaces have no scratches or other abnormalities.
- (7) Pull out all ⑬ Shims.
- (8) Remove the ⑫ Collar, ⑯ Disk, and the ⑰ Armature and clean the wear debris on the ⑪ Magnet ASSY with an air gun.
 - ※ Be cautious not to lose the spring.
- (9) Clean the screw hole of ⑪ Magnet ASSY with an air gun.
 - ※ Check to make sure the screw re-inserts easily after cleaning.
- (10) Apply adhesive on the screw to prevent looseness in the screw hole. (Recommended adhesive: Loctite 243 by Henkel)
- (11) Put all parts except for the shims back in their original positions and tighten the ⑭ Plate screw.
 - ※ Refer to the brake specifications list on the previous page for the tightening torque.
- (12) Check that the ⑱ Brake gap is within the initial gap of 「**■ Brake Specifications**」.
- (13) Check the operation of the brake (Brake release/brake actuation).

■ Brake Replacement Work

The brake gap adjustment described above can only be done once.

If the gap between the magnet ASSY and the armature exceeds the limitation gap with the disk wear after the gap adjustment, the brake must be replaced. Please contact your nearest service office.

For the brake replacement procedure, please check the replacement procedure included in the packaging of the new brake kit. However, please note that defects caused by brake replacement by a customer are not covered by our warranty.

■ How to Use a Manual Release Brake

- (1) Turn the manual release lever backward 60° to release the brake.
 - ※ Do not exceed 90° for releasing.
May cause release failure or interference to the parts.
 - ※ Turn the manual release lever while holding the lever fixing metal fitting.
Failure to follow this instruction may result in unexpected injury.
- (2) Be sure to return the lever to its original position (fixing position) after the manual release work is completed.

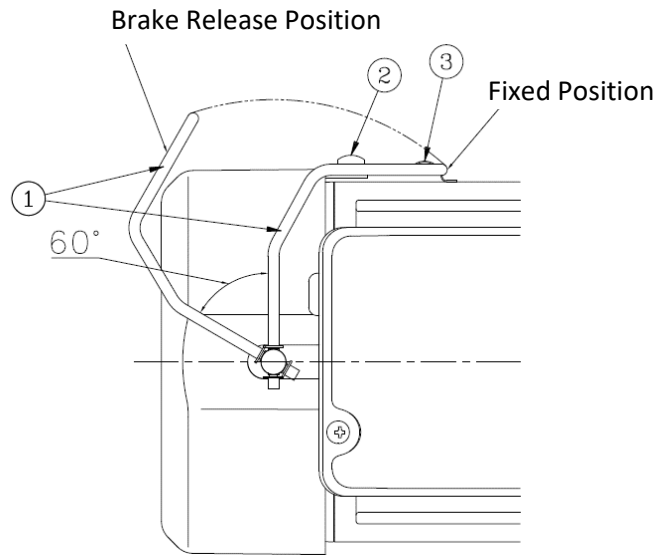

■ Precautions when using a Manual Release Brake

- Operate the manual release lever by hand.
- Do not carry the gearmotor by holding the manual release lever.
This may cause the lever to come off and result in you dropping the motor.

- ① Manual Release Lever
- ② Screw for Fixing Metal Fitting
- ③ Lever Fixing Metal Fitting

■ Warning Label

“Warning labels” with descriptions of precautions for handling the brake manual release device are attached to a gearmotor with a manual brake release device.

If the “Warning label” is peeled off or cannot be read, please immediately contact our nearest service office.

10.Troubleshooting

There are also malfunctions caused by the inverter other than contents shown below.
Read in conjunction with the inverter instruction manual.

■ Gearmotor Troubleshooting

Failure Detail	Cause	Measures
The motor does not run under no load	Power failure	Check the power supply. Contact the power company.
	Defective connection line	Inspect the circuit/wiring parts
	Defective contact of the switch	Repair or replace it
	Disconnection of the stator winding	Repair it at our factory
	1-phase power supply voltage	Check the terminal voltage
	Broken gear/shaft/bearing	Repair it at our factory
The motor does not turn when a load is applied	Voltage drop	Check the wiring length
	Worn gear	Repair it at our factory
	Overloaded operation	Lower the load
The motor generates abnormal heat	Overloaded operation	Lower the load
	Frequent startup/stop	Lower the frequency
	Damaged bearing	Repair it at our factory
	High/ Low voltage	Check the voltage
The sound is loud	Continuous sound - Damaged bearing/worn gear	Repair it at our factory
	Intermittent sound - Scratch on the gear, something inside the reducer	Repair it at our factory
The vibration is large	Worn gear	Repair it at our factory
	Defective installation/loose bolt	Tighten it
Grease leaks	Loose fastening part	Tighten it
	Damaged oil seal	Repair it at our factory

■ Gearmotor with Brake Troubleshooting

Failure detail	Cause	Measures
The brake does not work	Wrong connection	Check the connection
	Defective switch	Replace/repair it
The braking time is long	Oil/dust, etc. attached to the friction plate	Clean it or repair it at our factory
	Life time of the friction plate	Replace it or repair it at our factory
	Large load inertia moment	Lower the load
	AC switching connection	Change it to DC switching
The motor does not run (The speed is not increasing) The motor generates abnormal heat The thermal relay operates The brake sound is large	Wrong brake connection	Check the connection
	Large brake gap	Adjust the gap
	Defective rectifier	Replace it
	Brake coil disconnection or short circuit	Replace it or repair it at our factory
	Defective contact of the switch	Replace/repair it
The motor generates abnormal heat	Frequent braking	Lower the frequency
	Large load torque/inertia moment	Lower the load

■ Replacement Parts

For inquiries regarding brake-related parts, please contact our nearest sales or service office described on the last page of the instruction manual.

Defects caused by the replacement of the parts by a customer are not covered by our warranty.

11. Disposal

CAUTION



When disposing of the product, dispose of it as a general industrial waste. Please follow local laws and regulations if any apply and take care of the waste accordingly.

12. Storage

1. Storage place

- (1) When the product is stored, it shall be stored in a dry place indoors, with good ventilation, without direct sunlight, extreme temperature change, humidity, dust, and/or corrosive gas.
- (2) Do not directly place the product on the ground when it is stored.
- (3) If there is a micro vibration the bearing may be damaged by fretting corrosion even when the product is stored. Please store the product in a place without vibration.

2. Operation During Storage

- (1) To prevent the bearings from getting rusty, operate the motor every six months to check if the motor rotates smoothly and there is no abnormal sound.
- (2) Measure the insulation resistance with an insulation resistance tester with a 500V of the measuring voltage to check if it is 1 MΩ or higher.
- (3) Apply rust prevention to the output shaft and the flange side and other uncoated processed surfaces every six months.

3. Use After Storage

- (1) Check that there is no abnormal sound, vibration, heat generation and other abnormalities during the initial operation.
- (2) For gearmotors with a brake, check that the brake operates properly. If any abnormality is found, please immediately contact our nearest service office.

13. Warranty

1. Warranty Period

18 months from the factory shipment date or 12 months after installation; whichever comes first.

2. Warranty Coverage

- (1) The warranty coverage is limited to our production range.
- (2) If a failure that prevents function of the delivered product occurs under the conditions with normal installation/connection and handling (inspection/maintenance) described in this instruction manual during the warranty period, the product will be repaired without any additional cost.

However, NISSEI CORPORATION will not be liable for any costs for removing or installing our products from the user's device for replacement or repair, costs for transportation for repairs, and/or indirect damages.

3. Warranty Exclusions

- (1) Repair, part replacement or delivery of alternative products caused by product wear or disassembling and remodeling by customers.
- (2) When the product is operated under conditions that are outside of the rated data described in our catalog/instruction manual or specifications mutually agreed.
- (3) When there is a defect (centering of coupling etc.) in the power transmission part with the customer's device.
- (4) When inevitable accidents such as extraordinary natural disaster (Example: Earthquake, lightning, fire and flooding) or artificial malfunction is a cause of a failure.
- (5) Secondary failure caused by defects of customer's equipment.
- (6) Failure due to a part supplied by the customer or designated parts, drive units (Example: motor, servo motor, hydraulic unit, etc)
- (7) When storage, maintenance management of the delivered product is not performed properly and handling is not carried out correctly.
(Refer to "12. Storage" for descriptions of storage.)
- (8) Failure due to items that cannot be attributed to our manufacturing responsibility other than the above.

14. Notes on operating with inverters other than the specialized inverter

CAUTION



When disposing of the product, dispose of it as a general industrial waste. Please follow local laws and regulations if any apply and take care of the waste accordingly.

Read the followings carefully in case you use the inverter apart from our specialized inverter to operate an IPM gearmotor.

- Use inverters that can drive a PM motor.
- Refer to the inverter instruction manual for parameter settings.
- Torque characteristics(use limit) differs depending on the combination of inverter and settings.
- The maximum current to the motor is up to 150% of the rated current value of our motor.
Motor failure may occur when current greater than 150% is flown.
- Maximum rotational speed of the motor is 2500r/min.
- The minimum rotational speed differs depending on the inverter maker.
- Ask us regarding the gearmotor.
- Contact the inverter maker if you use inverters apart from our specialized inverter.
※Contact us for information regarding operation confirmed inverters.
- Refer to the table below for motor parameter settings.
※Refer to the inverter instruction manual for auto tuning.

(Reference values)

Motor Type	IPM Motor (Embedded Magnet Type Motor)							
Motor Power(kW)	0.1	0.2	0.4	0.75	1.5	2.2		
Number of Motor Poles	4			6				
Rated Current(A)	0.45	0.86	1.74	3.37	6.13	8.2		
Rated Rotational Speed(r/min)	1800(60Hz)			1800(90Hz)				
Max. Rotational Speed(r/min)	2500(83.3Hz)			2500(125Hz)				
Winding Resistance(Ω) ※1	14.297	14.297	4.264	1.824	0.81	0.606		
Induced Voltage	mV/min-1		81.1	81.1	77.8	76.1	82.2	90.6
Constant ※2	mV · s /rad		774	774	743	727	785	865
d Shaft Inductance(mH) ※1	82.3	82.3	40.2	8.26	5.06	3.85		
q Shaft Inductance(mH) ※2	138.7	138.7	67.8	11.72	9.83	7.55		

※1 Values shown per each phase. Double the value for between the lines

※2 This is the effective value between the lines; multiply the value by $1/\sqrt{3}$ for one equivalent.

Contact Us

■Inquiries for gearmotors

●Overseas Sales

1-1 Inoue, Izumi-cho, Anjo, Aichi 444-1297, Japan

Tel : +81-566-92-5312

Fax : +81-566-92-7002

E-mail: oversea@nissei-gtr.co.jp

Nissei Corporation