



GTR Gearmotor

G3 Series (Parallel Shaft)	H2 Series (Right Angle Shaft)	F Series (Hollow Shaft) (Solid Shaft)	F2 Series (Hollow Shaft) (Solid Shaft)	F3 Series (Hollow Shaft) (Solid Shaft)
-------------------------------	----------------------------------	---	--	--

Instruction Manual



G3 Series

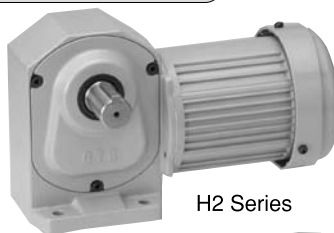

H2 Series



F Series•FS Type



F Series•FF Type



F2 Series•F2S Type
F3 Series•F3S Type





F2 Series•F2F Type
F3 Series•F3F Type

For Safe Operation

- The Gearmotor should be operated by a skilled and qualified person. And the contents of this Instruction Manual should be carefully read and understood before operating this product.
- This Instruction Manual should be delivered to a person who actually operates this product.
- This Instruction Manual should carefully be kept in a convenient place for the operator's easy reference.

Thank you for your purchasing our product.

In this Manual, injuries and damages anticipated in case of mishandling of the equipment, are classified into two categories, "Danger" and "Caution". The definition of the classification are given below with the corresponding graphic symbols.

 Danger	The case that mishandling of the equipment may result in dangerous situation and may lead to serious or fatal injury to personnel.
 Caution	The case that mishandling of the equipment may result in dangerous situation and may lead to medium to light injury, or the case that may result in damage to the equipment.

Please be aware that even items marked with "CAUTION" may cause fatal accidents. Therefore, be sure to follow the instruction, for every item described is very important.

Danger

- Be sure to use an explosion-proof motor where any explosive or flammable gases exist. Failure to observe this warning may cause explosion, spark, fire, electric shock, physical injury, and/or damage to the equipment.
- The operators in charge of transportation, installation, wiring, operation, maintenance, and inspection of the equipment should have enough knowledge and technical skill for the product. Failure to observe this warning may cause explosion, spark, fire, electric shock, physical injury, and/or damage to the equipment.
- Do not repair or wire the equipment with the electric power on. be sure to cut the power off the power supply before getting to work. Failure to observe this warning may cause electric shock.
- If the equipment is to be used in a system for human transport, be sure to furnish it with a protective device for safety. Failure to observe this warning may cause physical injury and/or damage to the equipment by accidental falling.
- If the equipment is to be used with an elevator, be sure to furnish with a safety device to prevent the elevator from accidental falling. Failure to observe this warning may cause physical injury and/or damage to the equipment.
- Be sure not to get water or oil/grease into the brake unit Failure to observe this warning may cause accidental falling and/or runaway accident by the decreased brake torque.

Caution

- Do not use a gearmotor under conditions other than specified in the nameplate or the product specifications. Failure to observe this warning may cause electric shock, physical injury and/or damage to the equipment.
- Do not insert your fingers or any other object into the aperture of the gearmotor. Failure to observe this warning may result in electric shock, physical injury, fire and/or damage to the equipment.
- Do not use the damaged gearmotor. Failure to observe this warning may result in physical injury and/or fire.
- Do not take off the nameplate.
- The manufacturer will not warrant and will not responsible for the product modified or repaired by the user himself.

Contents

1	Check at the unpacking	P. 3	8	Inspection and Adjustment	P.26
2	Transportation	P. 3	9	Troubleshooting	P.31
3	Installation	P. 4	10	Disposal	P.32
4	Connecting with Other Equipment	P. 5	11-1	Appendix (High-Efficiency Gearmotor for China)	P.32
5	Direction of Rotation	P.10	12	Warranty	P.32
6	Wiring	P.13		Support documentation	P.34
7	Operation	P.24			

1 Check at the unpacking

When unpacking a carton, please check up the followings. If you have any problems or questions, please do not hesitate to contact the dealer from which the product was supplied or a sales office.

Caution

Check whether the product is the same product as ordered. Installing a wrong equipment may cause physical injury and/or damage to the equipment.

- (1) The ordered products and the contents indicated in the nameplate are correct.
(Type, Reduction ratio, Motor capacity, Voltage, Frequency, etc.)
- (2) No accidental damage to the product during transportation exist.
- (3) Screws or nuts are not loose.
- (4) In case of gearmotor attached with brake, rectifier is enclosed.
(Not necessary in case of gearmotor with built-in rectifier attached with terminal box.)
- (5) In case of gearmotor with clutch/brake, one rectifier and two surge suppressor are enclosed.
- (6) In case of single-phase motor(S100•S100W), capacitor is enclosed.

2 Transportation

Danger

- When a product is lifted up for transportation, be sure not to enter underneath of the lifted product. Falling of product may cause serious injury.

Caution

- Be careful when transporting products to avoid falling down. When an eyebolt or eyeplate is provided with the gearmotor, be sure to confirm if there is any loosening before using it. After installing gearmotor to the other equipment, do not hoist the entire machine using an eyebolt. Failure to observe this warning may cause physical injury and/or damage to the equipment due to the damage of the eyebolt or falling down of the machine.
- Before lifting the gearmotor up, be sure to confirm its weight by nameplate, packing box, external configuration, catalogue, etc. Do not lift up gearmotor which has more weight than the one specified in the lift. Failure to observe this warning may cause physical injury by breaking of bolt, falling or tumbling of product, and/or damage to the equipment.
- In case of wooden box package, it is unstable to lift under the wooden box by using a forklift. Therefore it is recommended to belt over the wooden box for lifting.

3 Installation

Proper installation of a product will ensure reliable service and maximum life.

Caution

- Do not place any object inflammable near the gearmotor. Failure to observe this warning may cause fire.
- Do not place any object which may interfere with the ventilation around the gearmotor. Failure to observe this warning may result in abnormal overheating caused by the block off of the cool air, which may cause burn injury and/or fire.
- Do not step on a gearmotor or hang to it. Failure to observe this warning may cause physical injury.
- Do not touch the edge of the shaft of gearmotor or key groove in the bore with bare hands. Failure to observe this warning may cause physical injury.
- In equipments like food machines, which must avoid oil or grease, furnish with protective devices like oil pan, in order to protect from the oil leakage caused by failure or life of the manufactured products. Leaking oil may cause defective products.
- There is possibility scatter the wear debris or iron powders.
In case of installing to equipment which will have any issue due to contamination of foreign substance such as food equipment, please install preventive equipment.
This could harm the products.
- Vibrations come out from the installation surface of gearmotor or from other source should be minimized to under about 0.5G.

(1) Proper location for installation

Ambient Temperature: -10°C to 40°C [Note]

Ambient Humidity: 85% max.

Altitude: Sea level to 1,000m max.

Environment: Well ventilated place free from vapor and/or dust.

{ In the hazardous circumstances where any explosive and flammable }
gases exist, be sure to use an explosion-proof motor. }

Installation Location: Indoors

[Note] Motor capacity S100 (capacitor operation motor) will be 0°C to 40°C .

Target model : H2 series, F series and F3 series

Motor capacity : Single phase 100W

(2) Direction of Installation

This product can be installed in any direction due to a grease lubrication system.

(3) Method for Installation

① Attaching the mounting foot and flange

Fix the product with the four bolts on a flat and machined surface free from vibration.
(Roughness of the surface should be less than 0.3mm.)

② Attaching the shaft

● Gearmotor's weight should be supported by the driven shaft.

(Forces other than turning reactive force should never be imposed to the torque arm.)

● In case start/stop and forward/reverse actions are frequent, tightn up the torque arm with bolts to keep the locking hole not loose.

③ The type that combines the S-Type Reducer with the pressure resistant and explosion-proof gearmotor with brake produced by Mitsubishi Electric Corporation, exceeds the motor capacity limit. Therefore, be sure to fit the auxiliary which support the motor before installation.

(4) Tightening torque

fixing hole (mm)	bolt size	tightening torque (N·m) { (kgf·m) }
5.5	M 5	2.9 { 0.3 }
6.5	M 6	4.9 { 0.5 }
8.5	M 8	13 { 1.3 }
9	M 8	13 { 1.3 }
11	M10	25 { 2.6 }
13	M12	44 { 4.5 }
15	M14	69 { 7.0 }
18	M16	108 { 11.0 }
22	M20	294 { 30.0 }

4 Connecting with other equipment

⚠ Caution

- When connecting the gearmotor with a load, make sure of the alignment of shaft, the tension of the belt and parallelism of pulleys. In direct coupling, be sure to check whether the alignment of shaft is extremely precise. If a belt is to be used, be sure to adjust its tension properly. Also, before operation, inspect whether the setting bolts for pulleys and coupling are securely tightened. Failure to observe this warning may cause serious injury and/or damage to the equipment due to broken parts.
- Safe guards should be furnished around rotating parts to avoid danger to persons.

Loose fit is recommended for the couplers such as couplings, sprockets, pulleys, gears, etc., when attaching to the reducer, using the designated key materials.

1 Direct Connection

Connect the reducer to the other equipment precisely, so that the center of the shaft of both machines will be fully aligned.

- An example of gear coupling

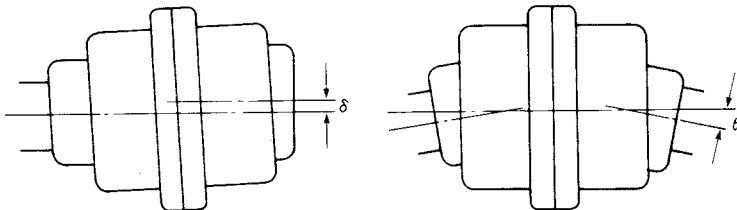

- The displacements δ and θ should be minimized as much as possible.
- The displacements δ and θ differ according to the type of coupling. Therefore, they should be within the allowable value defined by the respective manufacturer.
(Reference: In case of chain coupling, δ should be within 2% of the roller chain pitch and θ should be within 1° .)

2 Attaching Chains, V-Belts, Gears, etc.

- (1) In any connection, connect the units precisely, so that the center of the shaft of the reducer and that of the other equipment are parallel.
- (2) The tension of the Chains/V-Belts and the coupling of the gear must be perpendicular to the center of the shaft.
- (3) Tension of the V-Belt: Excessive tensioning may result in damage to the bearings of the shaft.
Tension of the Chain: Excessive tensioning may result in damage to the bearings of the shaft. If the chain is installed loosely, shock load will occur when the drive shaft starts rotation, and this can result in damage to the reducer and the other equipment. Therefore, adjust the tension of the chain properly.

Proper Way of Use

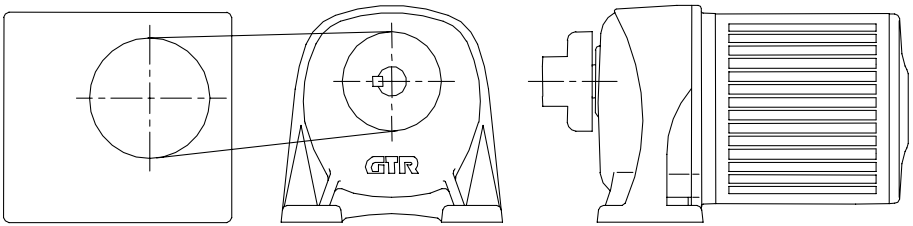

- connecting machine ● The tension of V-belt and chain are properly set, also pulley and sprocket are properly positioned.

Bad Example

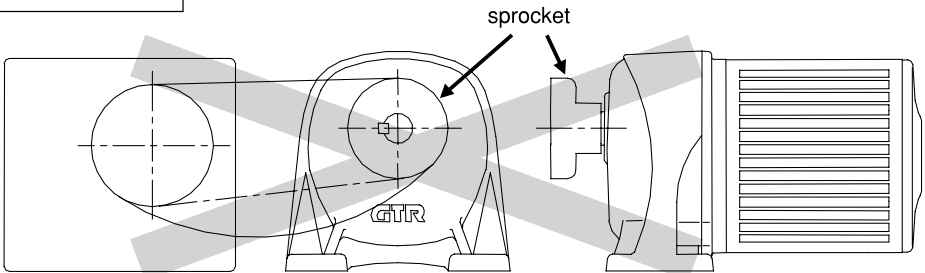

- connecting machine ● The chain is too loose.

- The sprocket is positioned in the reverse direction so that the load point moves to the shaft edge.

3 Attaching and Detaching a Driven Shaft to/from FS/F2S/F3S Type Hollow Shaft

●Attaching a Driven Shaft to the Reducer Hollow Shaft

- ①When attaching, be sure to smear extreme pressure agent(molybdenum disulfide, etc.) on the surface of driven shaft and the bore of the hollow shaft to avoid seizing, and insert the reducer to the driven shaft.
- ②In case impact does not apply in the uniform load, loose fit is recommended for the fit tolerance of driven shaft. In case shock load or heavy radial load is applied to the shaft, the fit should be tighter. The bore of the hollow shaft is machined to conform to "JIS H8" tolerance.
- ③If the fitting is too tight, for smooth insertion, knock on the hollow drive shaft end gently with plastic hammer. In this case be sure not to hit the casing. Smoother insertion can be obtained if you prepare jigs shown in the figure below.

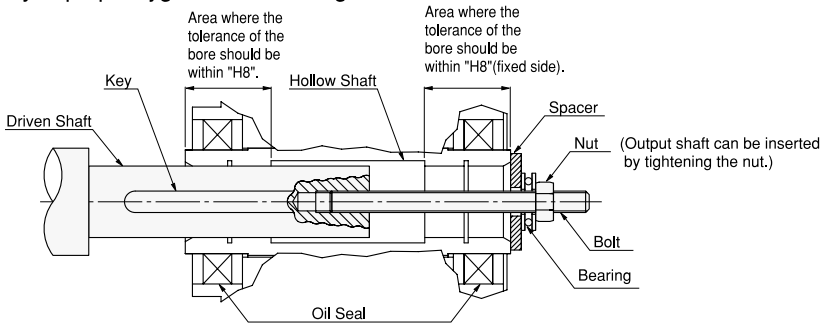

Figure-1

(Spacer, nut, bolt, key and other parts for bearing should be prepared by customer.)

- ④The length of the driven shaft and the fixing key are recommended to be within the area where "H8" tolerance for the fixed side bore is required.
- ⑤It is recommended to minimize the fluctuation of the driven shaft below 0.05 at the shaft edge. The greater fluctuation may give harmful effect to the reducer.

●Connecting Reducer with Driven Shaft

①Driven shaft with a shoulder

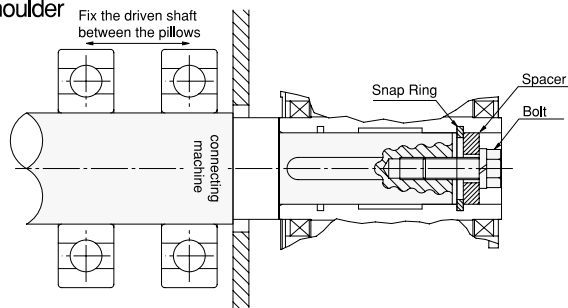

Figure-2 Fixing by spacer and snap ring

(Spacer, bolt and snap ring should be prepared by customer.)

Note) Excessive tightening of the bolt may cause the deformation of the snap ring, which carefully note.

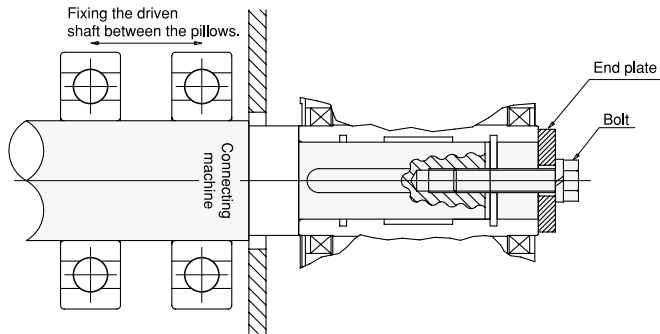

Figure-3 Fixing by End plate
(End plate and bolt parts should be prepared by customer.)

Note) The plastic cover which is an attachment of F-Series, cannot be attached, which please note. Safety measure such as preparing the protective cover, should be given by customer in order to avoid wind-in at the output shaft.

② Driven shaft without a shoulder

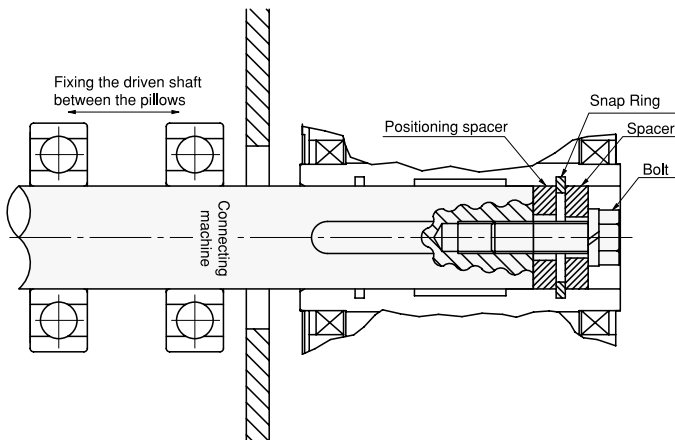

Figure-4 Fixing by spacer and snap ring
(Spacer, positioning spacer, bolt and snap ring should be prepared by customer.)

Note) Be sure to have space in the outer diameter of spacer and in the bore of hollow shaft. Excessive tightness of the fitting or inaccuracy of the spacer's diameter may be a cause of scrubbing which may lead to a greater fluctuation between the driven shaft and the hollow shaft. Positioning spacer is used when deciding the position of the reducer. In case the length of the driven shaft is already clarified, positioning spacer is not necessary. By having a positioning spacer, smoother detachment from the hollow shaft can be obtained. (For more details about the detachment from the hollow shaft, refer to Figure-5 on page 9.)

● **Recommended size for the driven shaft fixing part**

For the attachment of the hollow shaft in general use, we recommend you to refer to the dimensions shown on the right as a guide line for the strength when designing.

(Recommended size for the driven shaft fixing part)

Hollow Shaft Diameter Size	Bolt Size	Spacer Dimension			Nominal Designation for C-Type Snap Ring
		Outer Diameter	Inner Diameter	Width	
φ20	M6	φ19.5	φ7	3	20
φ25	M6	φ24.5	φ7	4	25
φ30	M8	φ29.5	φ9	5	30
φ35	M10	φ34.5	φ11	5	35
φ45	M10	φ44.5	φ11	5	45
φ50	M12	φ49.5	φ13	6	50
φ55	M12	φ54.5	φ13	6	55

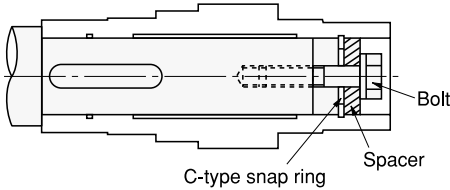

● **About the length of driven shaft**

The driven shaft must be reached to the both side of the L1 part. (As shown on the right figure) However, be sure to have allowance for the spacer's dimension necessary at the "detachment from the hollow shaft".

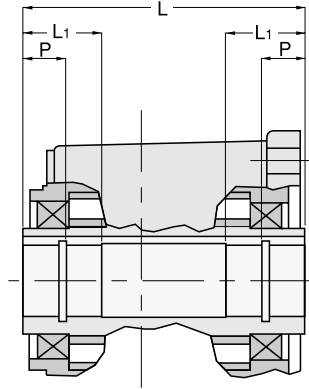

● **About the length of key for the driven shaft**

The length of the key should be more than 1.5 times of the diameter of hollow shaft. Also, the key inserting position should be the place where more than 1/2 of the total key length can be reached to L1. (Refer to the figure on the right)

● **Detaching from the hollow shaft**

Make sure to avoid excessive force between the casing and the hollow shaft. Smoother detachment can be obtained by using a jig as shown in the figure below.

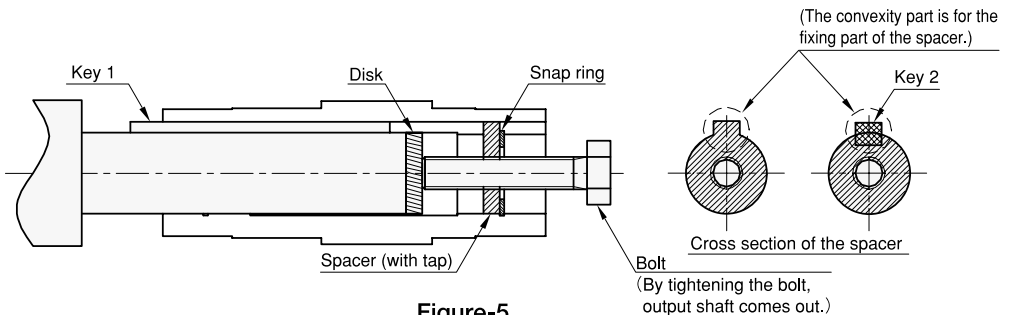

Figure-5

(Spacer, disk, bolt and snap ring should be prepared by customer.)

5 Direction of Rotation

⚠ Caution

Before coupling with the other machine, be sure to check the direction of rotation. Unexpected operation in wrong direction may cause serious injury and/or damage to the equipment.

In the GTR Reducer, the relations between the input shaft and the output shaft are as shown below:

●GTR G3 Series

0.1kW Capacity		0.2~2.2kW Capacity	
1/5 ~1/50	same direction	1/5 ~1/30	same direction
1/60 ~1/200	counter direction	1/40 ~1/200	counter direction
1/300~1/1200	same direction	1/300~1/1200	same direction

●GTR H2 Series

0.1·0.2 kW	1/5~1/60 And 1/600~1/1500
0.4·0.75kW	1/5~1/60 And 1/300~1/1500
1.5·2.2 kW	1/5~1/30

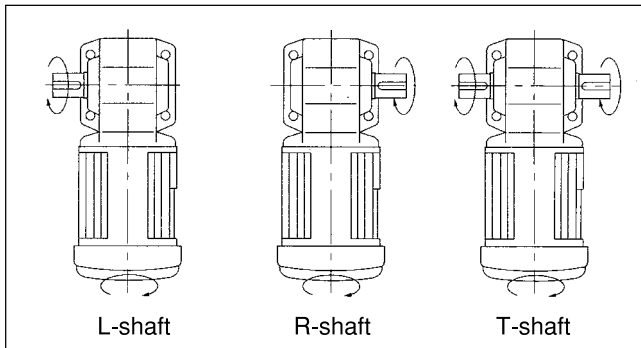

0.1·0.2 kW	1/80~1/450
0.4·0.75kW	1/80~1/240
1.5·2.2 kW	1/40~1/240

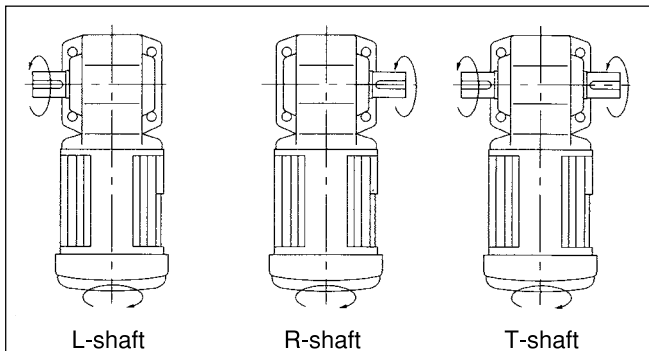

●GTR F-Series

50W 1/5~1/60 And 1/300~1/450
0.1~0.75kW 1/5~1/60 And 1/300~1/1500
1.5~2.2 kW 1/5~1/30

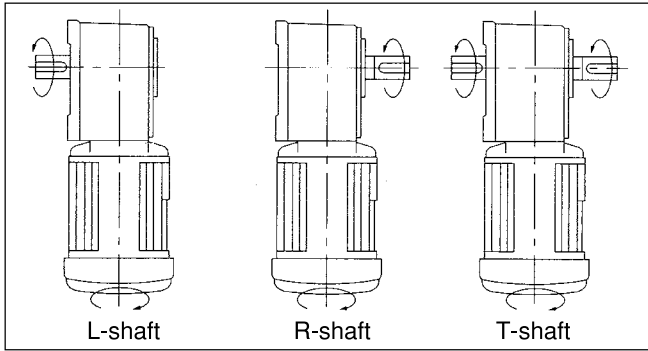

50W 1/80~1/240 And 1/600~1/1800
0.1~0.75kW 1/80~1/240
1.5~2.2 kW 1/40~1/240

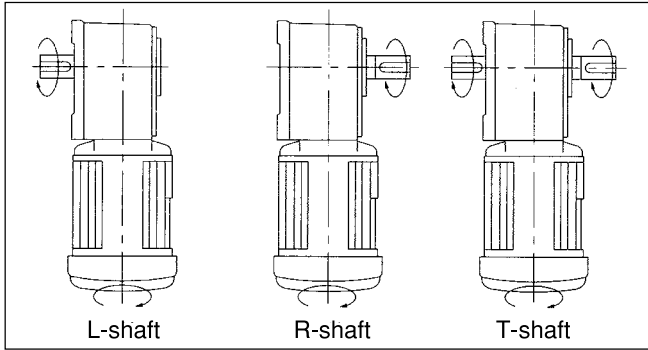

●GTR F2 Series

0.1~1.5kW 1/5~1/60

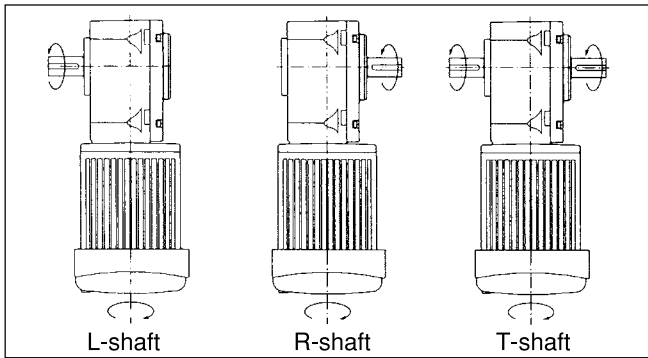

●GTR F3 Series

0.1kW	1/5~1/60 And 1/300~1/1500
0.2kW	1/5~1/60 And 1/300~1/1200
0.4kW	1/5~1/60 And 1/300~1/600
0.75kW	1/5~1/60 And 1/300
1.5•2.2kW	1/5~1/60

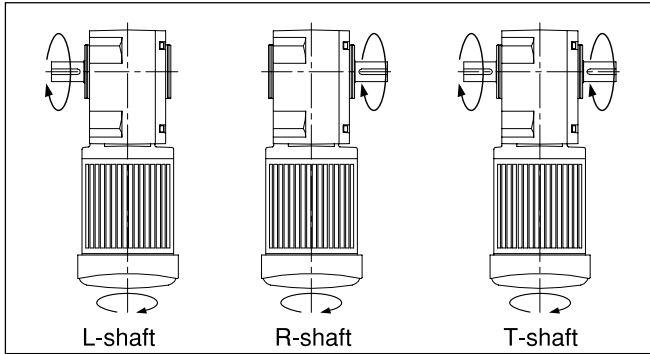

0.1~1.5kW	1/80~1/240
2.2kW	1/80~1/120

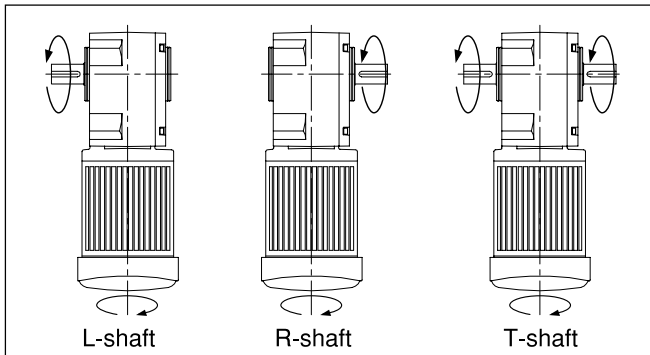

6 Wiring

1 Direct Connection



Danger

- When connecting the machine to the power cable, be sure to follow the instructions shown in the connection diagram in the terminal box or in the Instruction Manual. Failure to observe this warning may cause electric shock or fire. (In case of the type of no terminal box, be sure to insulate a wire at the terminal area.)
- Do not bend, pull or tuck down power cables or motor lead wires forcibly. Failure to observe this warning may cause electric shock.
- Be sure to ground the terminal of the earth wire. Failure to observe this warning may cause electric shock.
- Be sure to use the electric current source specified in the name plate. Failure to observe this warning may cause burnout of the motor and/or fire.



Caution

- Do not touch terminals when inspecting the insulation resistance. Failure to observe this warning may cause electric shock.
- Wiring should be properly made under the specified electrical equipment engineering standard or the safety code. Failure to observe this warning may cause electric shock, fire or physical injury.
- Our motor is not equipped with protective devices. The electrical equipment engineering standards provide that an overload protection device should be installed in a unit. Other protection devices such as circuit breaker are also recommended to be installed. Failure to observe this warning may cause damage to the equipment, electric shock, fire or physical injury.
- When rotating gearmotor alone, take off the key attached temporarily to the output shaft. Failure to observe this warning may cause physical injury.
- Check up the direction of rotation before connecting with the other machine. Rotation in wrong direction may cause physical injury and/or damage to the equipment.
- If a 400V class inverter is employed for motor drive, be sure to attach a control filter or a reactor to the inverter. The breakdown of insulation may cause damage to the equipment or fire.
- Do not misuse a capacitor for starting as the one for continuous motor running. This misuse may cause damage to the capacitor.
- Do not hurt the vinyl coating of starter capacitor. The hurt may cause electric shock.
- Voltage drops in the wiring should be kept within 2%. Excessive length of wiring may cause steep voltage drop and this makes the motor disable to start up.
- When reversing a gearmotor is required in operation, be sure to stop rotating and then start reversing. Reversing without complete rest may cause damage to the equipment.
- As for a gearmotor with brake, do not energize continuously to the brake unit during the rest of motor. The continuous supply may cause burning of the brake coil and fire.
- If a gearmotor with brake is used for the application such as lift, "DC Switching" wiring should be employed to avoid accidental falling.
- The 0.75 kW Certification of CCC terminal box outlet hole has the insulate rubber ring to protect the lead wire, please cut apart the surface of the rubber when connect the wire.

- (1) As the rectifier unit contains diodes, improper wiring may cause fatal short-circuiting and breakage of the unit. So, special care should be taken for wiring.
- (2) In case of DC switch is adopted, DC110V <DC220V>, contact rated DC13 class is recommended in order to cut off the inductive load (DC coil).
Please contact us for details.
*Contact rated DC13 class is the categorized in JIS C 8201-5-1 for low-pressure switchgear and control device.
*The capacity in the parenthesis < > is the one at 400V with brake (yellow lead wire).
- (3) In case of gearmotor with clutch/brake, use the relay with the capacity of more than the rated current of 1A (DC110V) at the contact point of brake and clutch.
- (4) The direction of rotation of the output shaft varies according to the speed reduction ratio of the gear head. Therefore, be sure to confirm the speed reduction ratio before wiring.
- (5) The voltage between the capacitor terminals of the single-phase motor will become nearly twice as much as that in the power source of the motor. Therefore be sure to insulate wires at the terminals for safety.

2 Wiring of gearmotor

For standard gearmotors, wirings described below are recommended:

The direction of rotation in the wiring below is clockwise viewed from the backward of the motor, which is forward.

In case of T50 and T50W with the reduction ratio of 1/300~1/1800, the direction of rotation will be counterclockwise.

■ 3-phase Motor/ Common to F, F2, F3, H2, G3 series

● Lead Wire Type

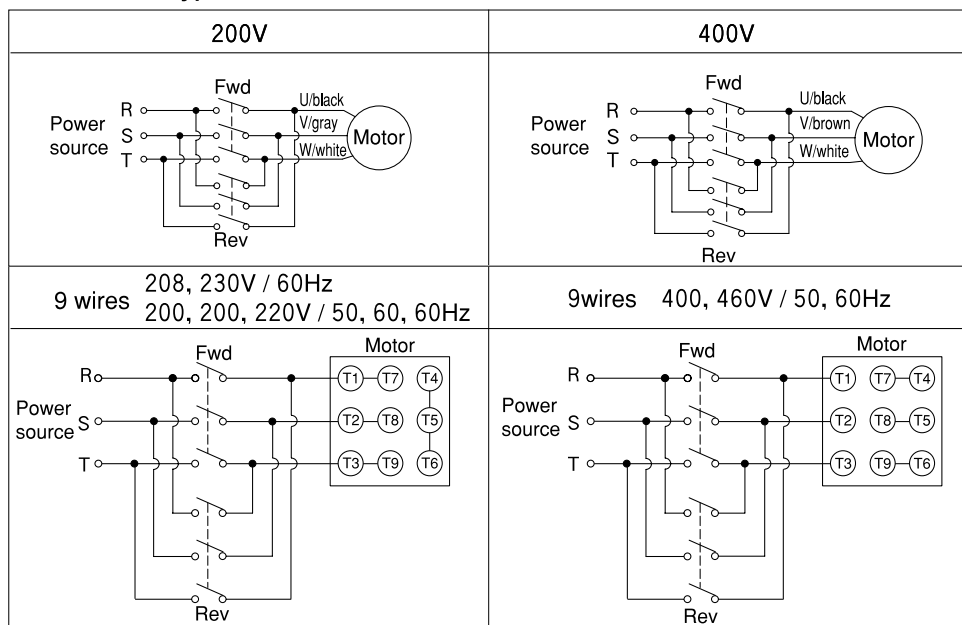

●Terminal Box Type (Common to 200V and 400V)

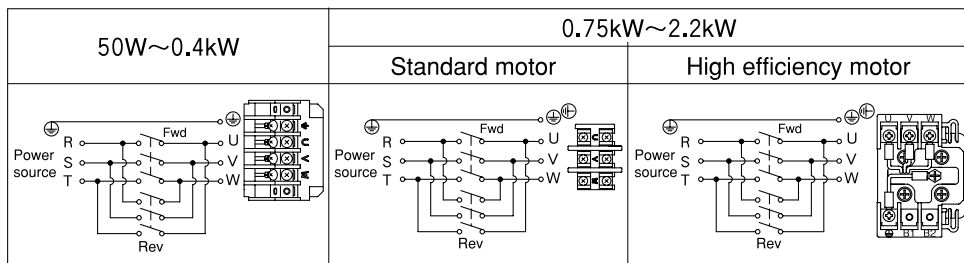

●Terminal Box Type (9 wires 0.75kW ~ 2.2kW)

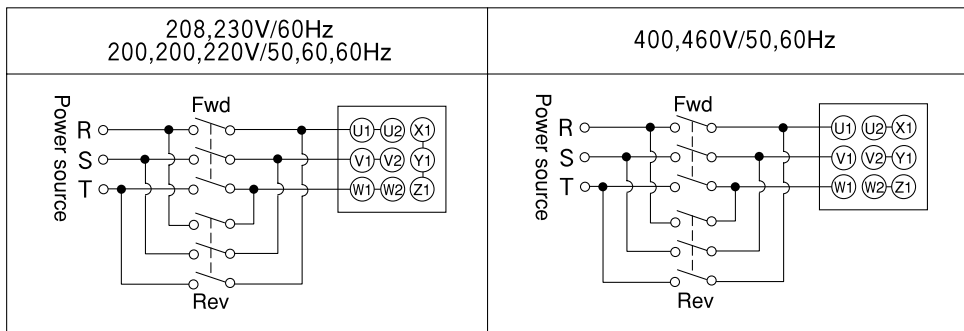

●Precautions for Terminal box/base.

- Please do not remove terminal box/base.
If the direction of the lead wire outlet needs to be changed, please contact Nissei's sales office.
- Please use the included nut and short bar for wiring.
Set the fastening torque for the nut at 1.2~1.5N·m {12~15kgf·cm}
- There is a rubber sheet for insulation on the terminal box lid.
Do not remove. May cause short circuit and/or electrocution
- The fastening torque for W-type boxes is set at 1.8~2.5N·m {18~25kgf·cm}.

■1-phase Motor/H2, F, F3 series

Motor Designation S100·S100W

●Lead Wire Type

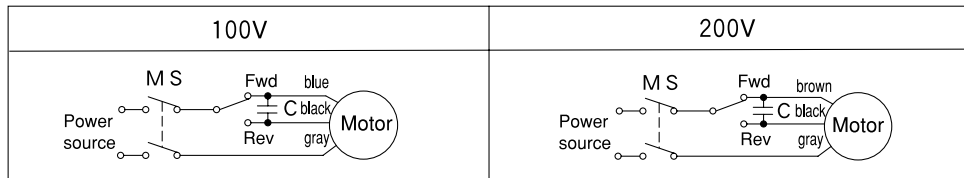

MS: Electro-Magnetic Switch C: Capacitor

● Terminal Box Type (Common to 100V and 200V)

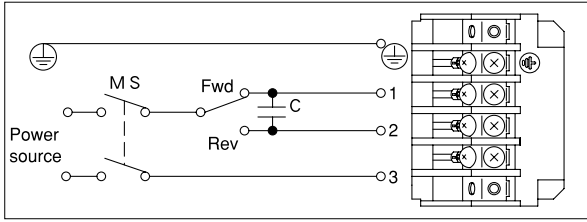

The motor designation, single-phase S100 · S100W adopt capacitor drive motor, therefore the starting torque should be 60~80%. For your information, the single phase S100·S100W need capacitor. Attached capacitor can be wired and used.

Capacitor

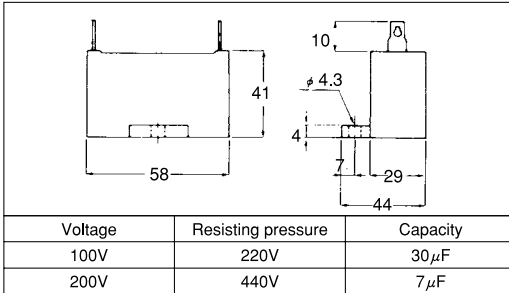

■ Single-phase Motor

G3Series/motor designation 100·200·400
 H2Series/motor designation 200·400
 FSeries /motor designation 200·400
 F3Series/motor designation 200·400

■ Single-phase Motor

G3Series/motor designation 100W·200W·400W
 H2Series/motor designation 200W·400W
 FSeries /motor designation 200W·400W
 F3Series/motor designation 200W·400W

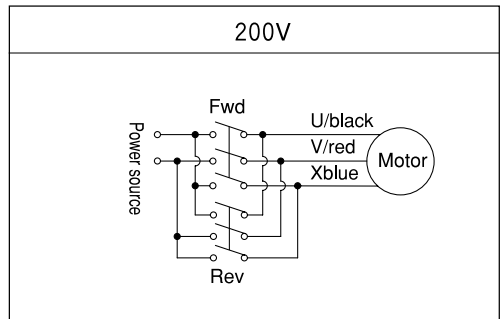
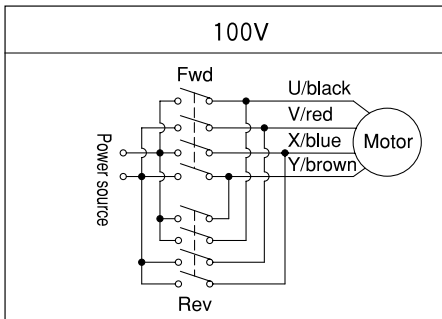

3 Wiring for gearmotor with brake

- (1) If a gearmotor is used in the applications where quick braking is required, such as lift, "DC Switching" wiring should be employed.
- (2) In case of "DC Switching" wiring, it is recommended to insert the surge suppressor in-between the connecting points.(Varistor voltages are 423~517V at 200V brake and 820~1,000V at 400V brake.)
- (3) The brake voltages are DC 90V for 200V brake(blue lead wire) and DC 180V brake for 400V brake(yellow lead wire).

- (4) In case of DC switch is adopted, DC110V <DC220V>, contact rated DC13 class is recommended in order to cut off the inductive load (DC coil). Please contact us for details.
 *Contact rated DC13 class is the categorized in JIS C 8201-5-1 for low-pressure switchgear and control device.
 *The capacity in the parenthesis < > is the one at 400V with brake (yellow lead wire).
- (5) As the rectifier unit contains diodes, improper wiring may cause fatal short-circuiting and breakage of the unit. So, special care should be taken for wiring.
- (6) When wiring 3-phase double voltage 200V with brake(blue lead wire) special voltage of over 230V, since the 200V terminal (red lead wire for 50W~0.4kW black lead wire 0.75~2.2kW for B terminal) is taken out of the motor, connect this 200V terminal with the input terminal of the rectifier (white, yellow).
 *Please refer to the wiring diagram below.
- (7) The wiring of brake is 200V with brake blue lead wire for 50W ~0.4kW,
 400V with brake yellow lead wire for 50W ~0.4kW, 0.75kW~2.2kW for terminal (B1·B2)

● Brake lag : ta

This is the time consumed from the moment of "switch off" to the moment of start braking, (and is different from the braking time.)

No.	motor designation 3-phase [T50 ~T040 ·075] 3-phase [T50W~T040W·075W]	motor designation 3-phase [150 ·220] 3-phase [150W·220W]	motor designation 1-phase [S100·100 ~400] 1-phase [S100·100W~400W]
(1) DC Switching	0.005~0.015	0.005~0.020	0.005~0.015
(2) AC Switching (A)	0.03~0.10	0.05~0.15	0.03~0.10
(3) AC Switching (B)	0.1~0.2	0.2~0.4	0.1~0.2

■ 3-phase

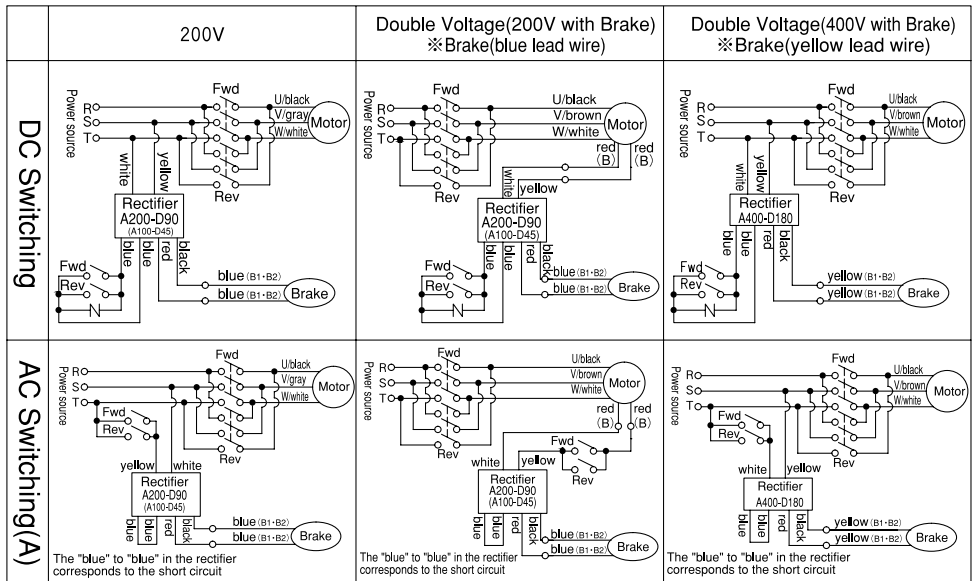

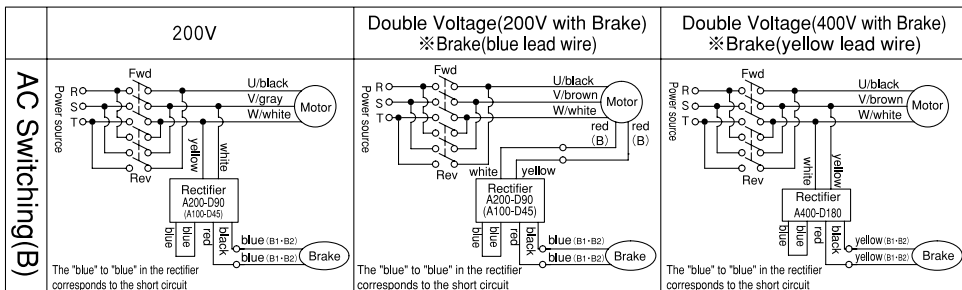

—|— : Surge Suppressor (option)

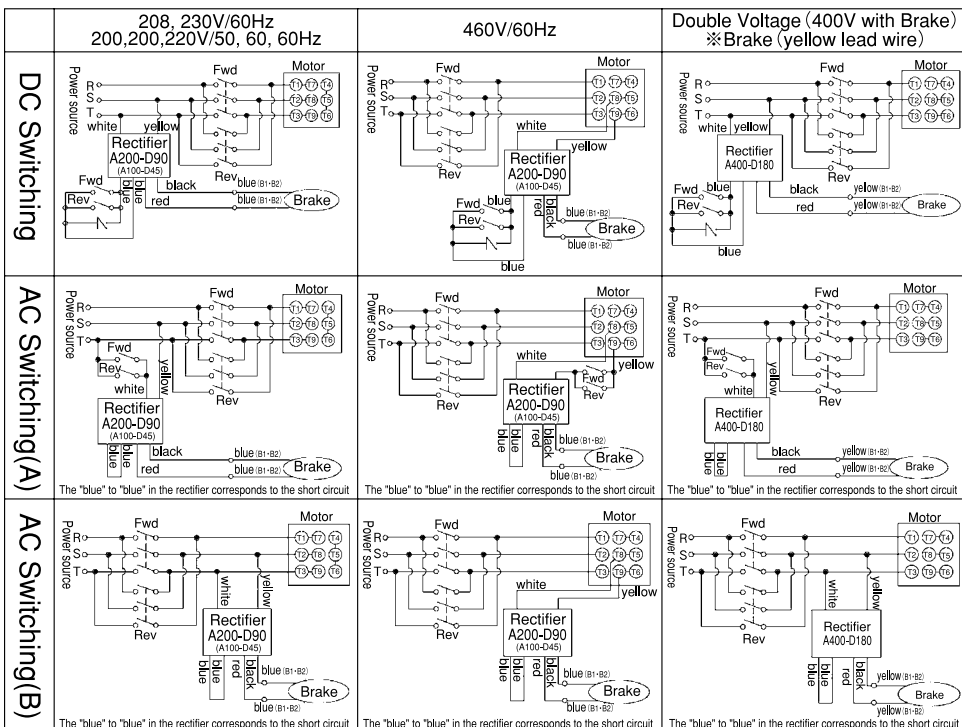

● Products with 9 leads and with capacities of 0.75kW~2.2kW will have a terminal box.

The prints on the terminal will be different from the lead wire type, so please refer to the diagram below when wiring.

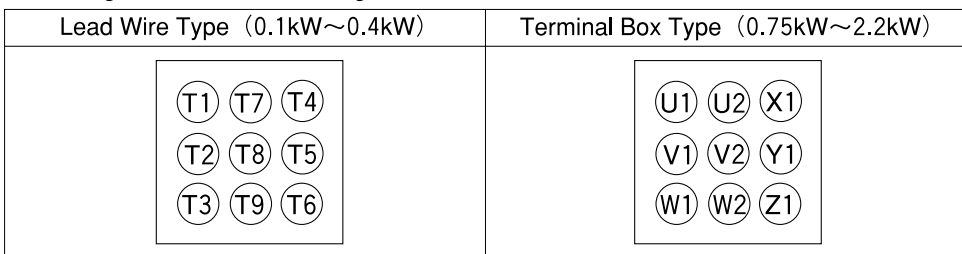

■ Info regarding stud type terminal box with integrated rectifier (custom-made)

	A:208, 230V /60Hz L:200, 200, 220V /50, 60, 60Hz	A:460V /60Hz, 400V /50Hz ※400V with Brake
AC Switching (B)		
DC Switching		
AC Switching (A)		

(Note) Please read " [3] Wiring a gearmotor with a brake".

■ Single-phase / H2 · F · F3 Series

Motor capacity S100 · S100W

	100V	200V
DC Switching		
AC Switching (A)	<p>The "blue" to "blue" in the rectifier corresponds to the short circuit</p>	<p>The "blue" to "blue" in the rectifier corresponds to the short circuit</p>

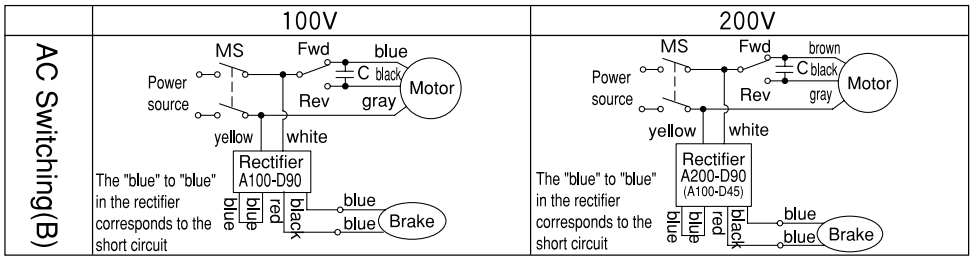

■ Single-phase / G3 · H2 · F · F3 Series
 Motor capacity 100~400 · 100W~400W

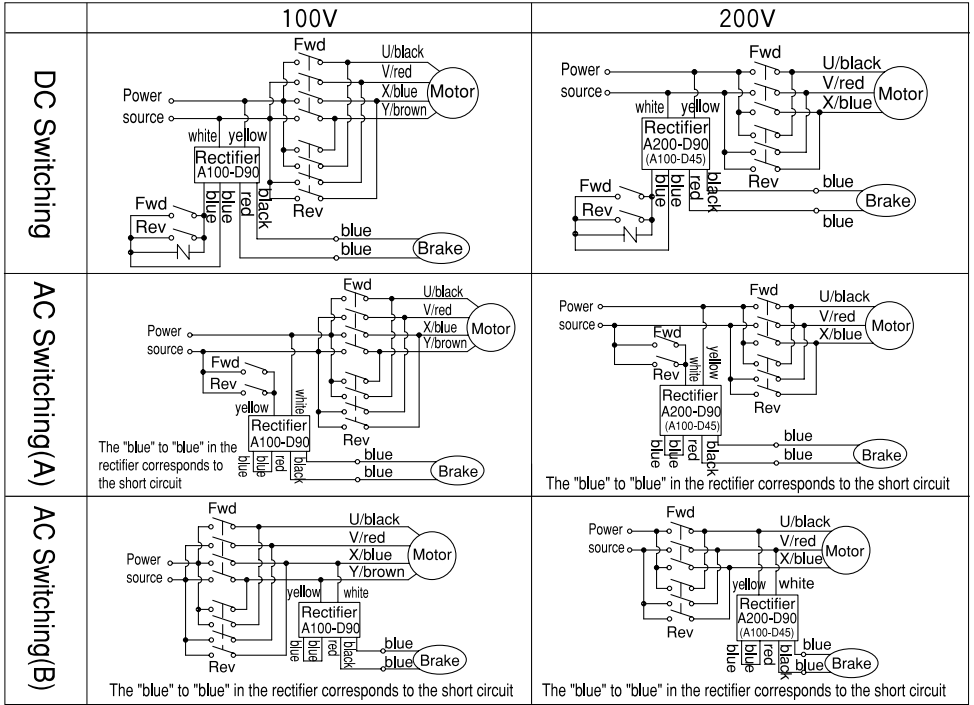

—N—: Surge Suppressor (option)

● Wiring method to a Z type terminal box

- ① In the Z type terminal box, a rectifier is built-in, so that the wiring is set as "AC Switching(B)". Therefore, the brake becomes effective only by connecting the terminal to 3-phase current or single-phase current. (The connecting board is attached to the switch.)
- ② When changing to "DC Switching" wiring, remove the connecting board.
- ③ In case of 3-phase double voltage 200V with brake(blue lead wire) "AC Switching(A)", the 200V terminal (red lead wire) is taken out from the motor. (But it is not fixed to the terminal board.)
 ※ "AC Switching(A)" is a product for custom-made. For more details, please contact us.
- ④ When using inverter, connection between "AC Switching(B)" and "DC Switching" is not feasible. For details, please refer to the wiring diagram of the gearmotor with brake in operation with inverter (page 20) or the handling manual of inverter. (This does not apply to the single-phase.)
 ※ In the category of the 3-phase double voltage 400V with brake(yellow lead wire), there is no model with Z-type terminal box available, which please note.

Motor capacity T50~T040・T50W~T040W

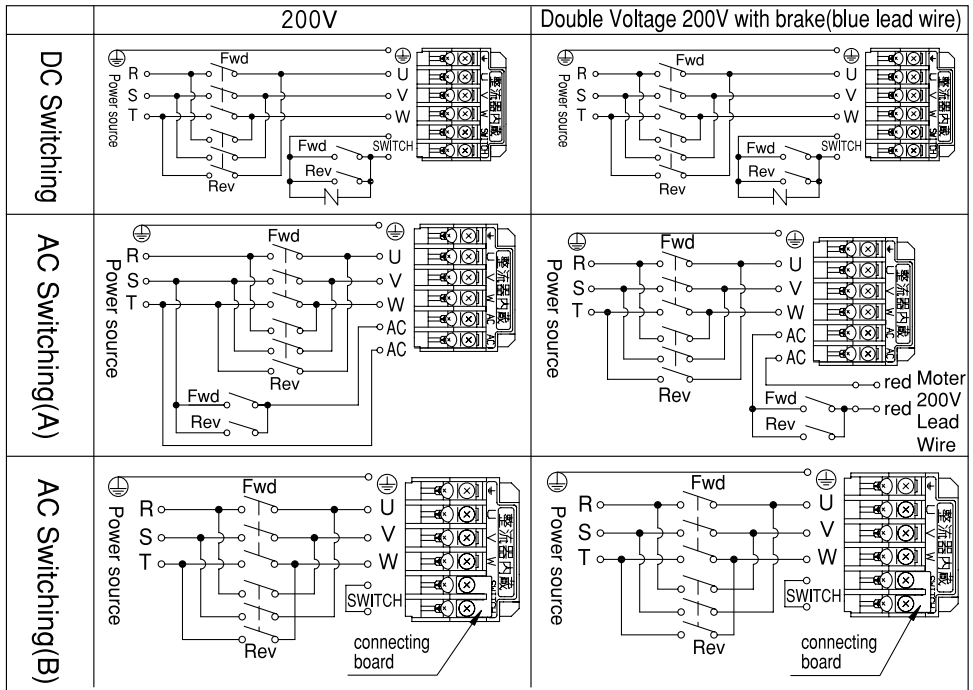

—N— : Surge Suppressor (option)

4 Wiring for the gearmotor with clutch/brake

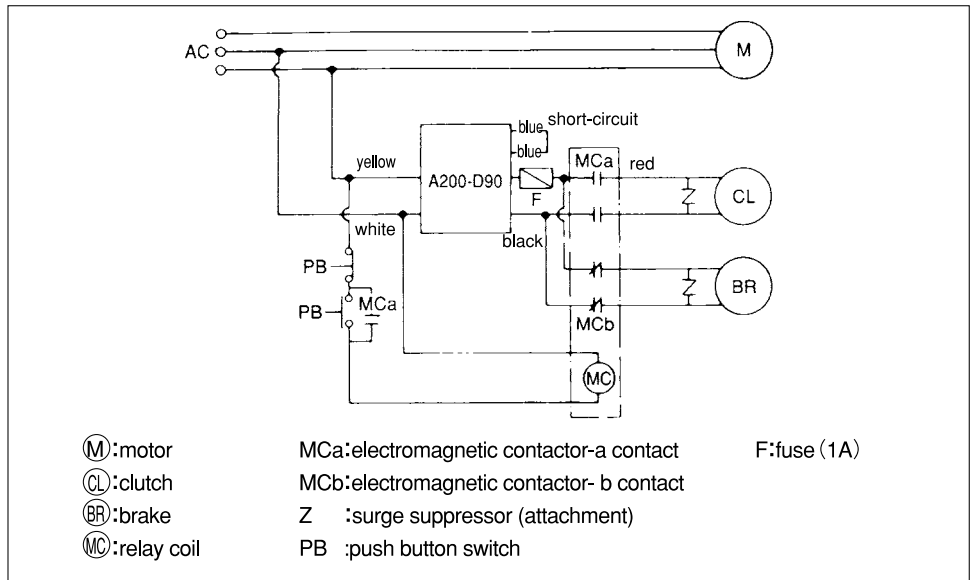

- (1) When wiring special voltage of over 230V, since the 200V terminal (red lead wire for 50W~0.4kW black lead wire 0.75~2.2kW for B terminal) is taken out of the motor, connect this 200V terminal with the input terminal of the rectifier (white, yellow).
- (2) Brake voltage corresponds to DC90V.
- (3) Be sure to avoid the usage of up and down operations. (Failure to observe this warning may cause accidental falling when power cut occurred.)

5 Cautions in operation with inverter

- (1) Higher temperature rise, noise and vibration than that from the general power source will be observed. Especially, low speed rotation which naturally reduce the fan effect, may cause abnormal rise of temperature. (More than 80°C at the surface of the motor)
- (2) In the gearmotor with brake or with clutch/brake, malfunction of the brake may be observed due to the voltage drop. In order to avoid this disadvantage, be sure to bypass the inverter when wiring the brake and clutch.
- (3) It is not feasible to use inverter in the single-phase motor.
- (4) When using inverter in the wiring of special voltage of 3-phase double voltage 200V with brake(blue lead wire) or in the wiring of over 230V, do not use the 200V terminal(red lead wire, 0.75~2.2kW for B terminal) taken out from the motor. It is recommended to insulate the terminal. The power source for the brake should be prepared separately.
- (5) When using inverter in the 400V class motor, consult with inverter manufacturer concerning the micro surge voltage.
- (6) The wiring of brake is 200V with brake blue lead wire for 50W ~0.4kW, 400V with brake yellow lead wire for 50W ~0.4kW, 0.75kW~2.2kW for terminal (B1•B2)

	3-phase 200V with brake lead wire type	3-phase 200V Z type terminal box type	3-phase double voltage 400V with brake(yellow lead wire)
AC Switching(A)		<p>Note, "AC switching (A)" for Z type terminal box is custom-designed specification. Therefore, special instruction is needed when ordering.</p>	
DC Switching		<p>* DC Switching wiring is feasible only for lead wire type.</p>	

MS: Electoro-Magnetic Switch $\text{---}\text{N}$: Surge Suppressor(option)

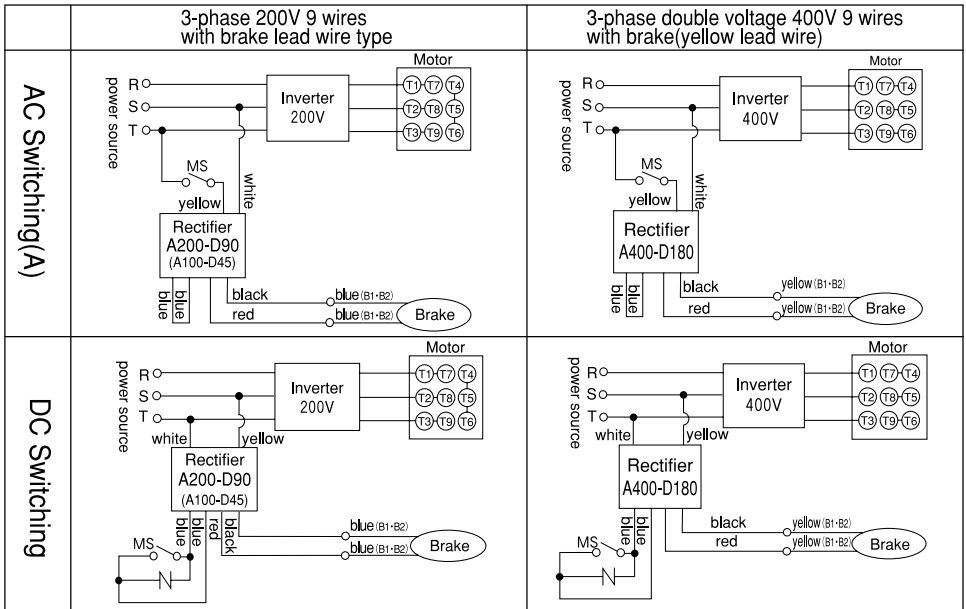

MS: Electoro-Magnetic Switch —N— : Surge Suppressor(option)

● Products with 9 leads and with capacities of 0.75kW~2.2kW will have a terminal box.
The prints on the terminal will be different from the lead wire type, so please refer to the diagram below when wiring.

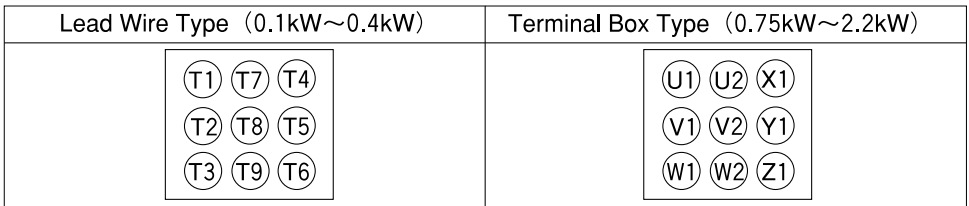

6 Attaching motor to S-Type Reducer

●Attaching Procedure

- (1) Confirm if the key is precisely inserted in the input pinion.
- (2) Fit the key position to the key groove (flat part) of the motor shaft and insert the key.
- (3) Confirm if the bore of the motor perfectly fit in, and then tighten with 4 bolts.

●Cautions on the attaching of the motor

- (1) Wipe off all the rust, dust and anti-seizing agent.
- (2) When attaching motor, do not hit the motor part or reducer part, nor forcibly insert taking advantage of the tightening force of the bolt. Failure to observe this warning may cause damage to the bearing and/or abnormal noise due to the key run on the key groove.
- (3) Input pinion key is not attached to the S-Type Reducer, therefore use the key of the motor. However, in the 0.1kW~0.2kW, key is attached.
- (4) Motor mass limit (guideline)

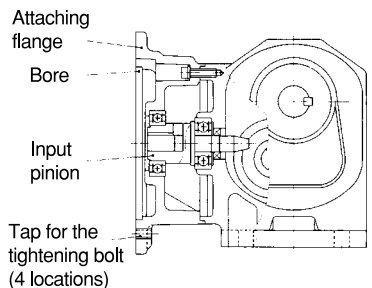

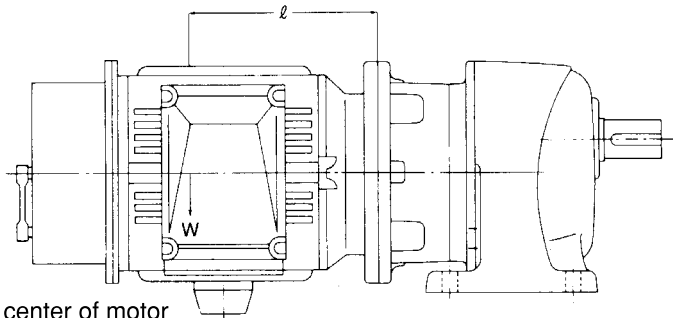

l : Gravity center of motor
 M : Mass of motor
 (W : Weight of motor)

Equivalent to 4P motor capacity	$l \times M$ { $l \times W$ }
0.1、0.2	27N·M {2.8kgf·m} and below
0.4	31N·M {3.2kgf·m} and below
0.75	34N·M {3.5kgf·m} and below
1.5	83N·M {8.5kgf·m} and below
2.2	93N·M {9.5kgf·m} and below

[Notes]

- (1) The limit of vibration that gearmotor can bear is considered to be 0.5G max. In case vibration given from the installation surface or from external source is greater than 0.5G, or if it is far beyond the motor mass limit, casing may be damaged and motor may fall down. In order to avoid such situation, motor supporting device should be mounted by customer before installation.
- (2) Before using gearmotors, carefully read this Instruction Manual and understand the contents. Failures of gearmotors caused by installation circumstances shall not be warranted.

7 Operation

⚠ Danger

- Do not operate gearmotors with the terminal box cover opened. Be sure to close the cover just after the wiring is completed. Failure to observe this warning may cause electric shock.
- Do not approach or touch rotating parts such as a shaft while the machine is running. Failure to observe this warning may cause wind-in and physical injury.
- If power cut occurs, be sure to switch off the power supply of a machine promptly, otherwise unexpected recovery of electric service may cause physical injury and/or damage to the equipment.



Caution

- The gearmotor becomes rather hot during operation, so do not touch it with bare hands. Failure to observe this warning may cause burn injury.
- When a gearmotor is found abnormal, stop running immediately. Failure to observe this warning may cause electric shock, physical injury or fire.
- Do not overload a gearmotor. Failure to observe this warning may cause physical injury and/or damage to the equipment.
- Do not touch the current-carrying part of the starter capacitor in single-phase motor until it has been discharged completely. Failure to observe this warning may cause electric shock.
- When a single-phase motor is to be reversed, be sure to start reversing after complete rest of the motor. Otherwise, direction of rotation may not change and may cause running out of control.
- Do not stop a motor forcibly. It may cause damage to the connecting machine. In a single-phase motor, this may make the motor rotate in the opposite direction and may cause running out of control.

1 Check up matters before turning the power switch on:

- (1) Wirings and connections are done properly.
- (2) Fuses and thermal relays of proper capacities are used.
- (3) Installations and the connections with other machines are properly done.
- (4) Earth terminal is properly grounded.

2 Check up matters at test running:

- (1) Confirm the direction of rotation for 1~2 seconds after starting the motor with unloaded condition. When you find the rotation in the opposite direction, change the wiring according to the diagrams shown in page 14-19.
- (2) Practice running-in of the motor with unloaded condition. When no defect is observed, add load gradually and eventually start operation with full load.

3 Check up matters during operation:

- (1) Confirm that there is no abnormal noise and vibration at all. When such defects are observed, stop operation immediately. Failure to observe this warning may cause physical injury and/or damage to the equipment.
- (2) Confirm if the surface temperature of the gear case or motor frame does not exceed 80°C. Do not touch the surface with bare hands. Failure to observe this warning may cause burn injury.

8 Inspection and Adjustment



Danger

- When inspecting and/or adjusting the machine while it is in operation, do not touch rotating parts such as a shaft. Failure to observe this warning may cause wind-in and physical injury.
 - Do not remove the cover of inspection window while the machine is in operation. Otherwise, blowout of hot lubricant may cause burn injury.
 - When inspecting the gear touch surface, be sure to lock up the drive and driven units beforehand. Failure to observe this warning may cause wind-in to the gear-teeth and physical injury.
 - In case of getting into closed equipment to inspect its condition, be sure to lock up drive and driven units and confirm whether the equipment is sufficiently cooled down beforehand. Also, keep on ventilating while inspecting inside. Furthermore, while inspection, be sure to staff supporting personnel outside to watch the safety conditions and keep in touch with the inspector inside. It can be very slippery with lubricant inside the equipment, so special attention should be given to safety. Failure to observe this warning may cause physical injury.
 - Do not operate the equipment with the safe guard off for inspection. Failure to observe this warning may cause wind-in and physical injury.
- [Inspection and Maintenance of Brake Part]
- Do not operate the equipment while releasing brake by manual releasing lever. Failure to observe this warning may cause accident by falling down of the equipment or by running out of control.
 - Before actual operation of the equipment, make sure the brake is functioning properly by turning the switch on and off. Failure to observe this warning may cause accidental falling and run out of control.
 - Do not operate the equipment without fan cover (or brake cover) after inspection and adjustment of brake gap. Failure to observe this warning may cause wind-in and physical injury.
 - Do not release the brake while the equipment is being loaded in the application such as lift. Failure to observe this warning may cause accidental falling.



Caution

- When measuring the insulation resistance, do not touch the terminals. Failure to observe this warning may cause electric shock.
- Surface of a gearmotor becomes very hot. Therefore, do not touch it with bare hands. Failure to observe this warning may cause burn injury.
- When measuring the insulation resistance of an explosion-proof type motor, confirm that there is no gas, steam, or other explosive substance around the unit. Failure to observe this warning may cause explosion or ignition.
- When operation being found abnormal, diagnose the fault according to the instruction manual. Do not operate the machine until the causes of fault are found and proper measures are taken.
- Repairing, disassembling and assembling of the equipment should be done by an experienced technician. Failure to observe this warning may cause electric shock, physical injury or fire, etc.

[Note] In case you need to change grease, oil seal or o-ring for the purpose of maintenance or inspection, be sure to ask our local office nearest to you. Please be noted that we will not be responsible for the defects caused by user's changing of above lubricant or parts.

1 Daily Inspection: Following items should be inspected every few days.

Inspection Item	Method	Details of inspection
Load current	Ammeter	Within the rated current specified in the name plate.
Noise	Hearing by person Detection rod	No abnormal sound such as rumbling sound or periodic sound. Acoustic detection rod makes it easier to catch the abnormal sound.
Vibration	Touching by person.	No abnormal vibration in the gear case and motor frame.
Surface temperature	Thermometer	Should be 80°C max.
Oil Leak	Visual Check	No lubricant leakage from the joint part such as case, oil seal or bracket, etc.

2 Periodic Inspections: (In case of operating 8 hours a day)

Inspection Item	Interval	Details of inspection
Fixing Bolt	6 months	Check the looseness of bolt and retighten.
Chain and V-Belt	6 months	Check the tension(loose or tight) and adjust it to the proper tension.
Insulation Resistance of Motor	6 months	Should be more than 1MΩ when insulation resistor shows 500V.
Brake	Brake Gap (Clearance)	1 year or 1~1.5 million cycles Check if the gap is within the allowable limit of proper gap. Adjustment should be done according to the instruction described in page 25-26.
	Friction Disk	1 year Check the thickness of the Friction Disk. When the thickness of the friction disk becomes less than 1.5mm, replace it with new disk or repair it in the authorized factory.

When any abnormality is found during the daily inspection, take proper measures according to the “Troubleshooting” (page 28) of this Instruction Manual.

3 Method for brake gap adjustment

 Danger	
1	When adjusting the gap, be sure to disconnect the motor from the power source. Failure to observe this warning may cause physical injury. In the event of the castellated nut removed, be sure to attach it in the right direction. Attaching in the wrong direction may cause damages. For the right attaching direction, refer to the attaching direction of the castellated nut in page 26.
2	After inspection and adjustment of the gap, be sure to confirm if the brake functions properly by turning the switch on and off. Failure to observe this warning may cause accident by falling or run out of control.
3	After inspection and adjustment of the gap, do not operate the motor with the fan cover (or brake cover) open. Failure to observe this warning may cause wind-in and physical injury.

(1) Method for brake gap adjustment for gearmotor with brake

After operation for an extended period of time, the friction disk of brake becomes abraded and the gap (g) increases. When the gap clearance becomes greater than the limit of gap to inhale, armature inhaling becomes difficult by magnet, making it impossible to release the brake. When using the motor continuously with this condition, the operation with brake-on causes excessive temperature rise and finally causes brake failure. In order to operate this machine safely, it is recommended to check or adjust the brake gap periodically (Every 1 year or every 1~1.5 million cycles).

Method for Gap Adjustment (Motor Designation T50 · T50W)

● Reduction Ratio of below 1/240

- ① Remove brake cover.
- ② Loosen setscrew and remove friction disk assembly.
- ③ Insert a plate 0.2~0.3mm thick in the gap between the field and the armature. Then put on and press down the friction disk assembly.
- ④ Seal the setscrew with locking agent and tighten it.
- ⑤ Remove the plate 0.2~0.3mm thick.

● Reduction Ratio of over 1/300

- ① Remove fan cover.
- ② Loosen setscrew and remove fan/friction disk.
- ③ Insert a plate 0.4~0.5mm thick in the gap between the field and the armature. Then put on and press down the fan/friction disk.
- ④ Seal the setscrew with locking agent and tighten it.
- ⑤ Remove the plate 0.4~0.5mm thick.

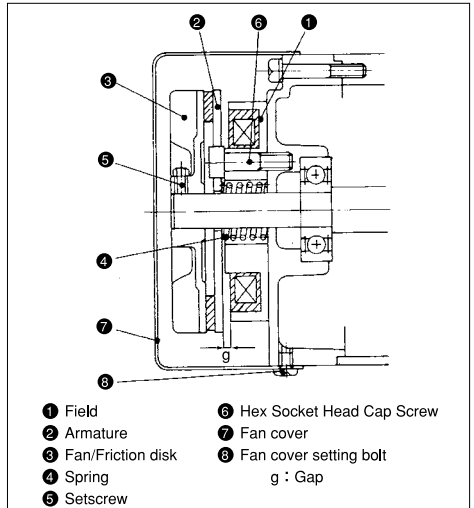
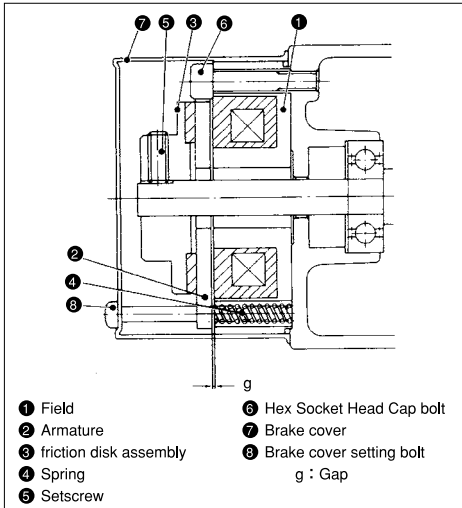

Motor Designation		Inhale Gap	Proper Gap
3-phase	Single-phase		
T50·T50W Reduction Ratio: below 1/240	—	$g: 0.5$ and less	$g: 0.2 \pm 0.1$
T50·T50W Reduction Ratio: over 1/300	—	$g: 0.8$ and less	$g: 0.4 \pm 0.1$

Method for Gap Adjustment

- ① Remove fan cover.
- ② Raise the tooth of castellated nut from fan/friction disk and then remove it. (In case of 1-phase motor, you must also loosen setscrew.)
- ③ Tighten the castellated nut until it is slightly locked.
- ④ Then, turn back the nut to the loosening direction at about $100^{\circ} \sim 180^{\circ}$.

In the event of the castellated nut removed, be sure to attach it in the right direction.

(Refer to the figure on the right, which shows the attaching direction of the castellated nut. / This does not apply to the T50 and T50W.) And confirm if the gap clearance is proper, by using gap gauge.

- ⑤ Fold the tooth of castellated nut into the nearest slot and tighten the setscrew (in case of 1-phase motor).

Attaching direction of the castellated nut.

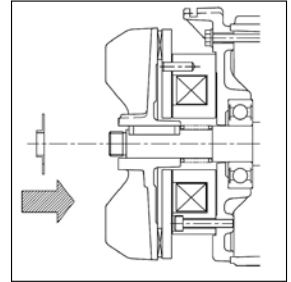

Motor Designation

3-phase/T010•T020•T040•075•T010W•T020W•T040W•075W
Single-phase/S100•100•200•400•S100W•100W•200W•400W

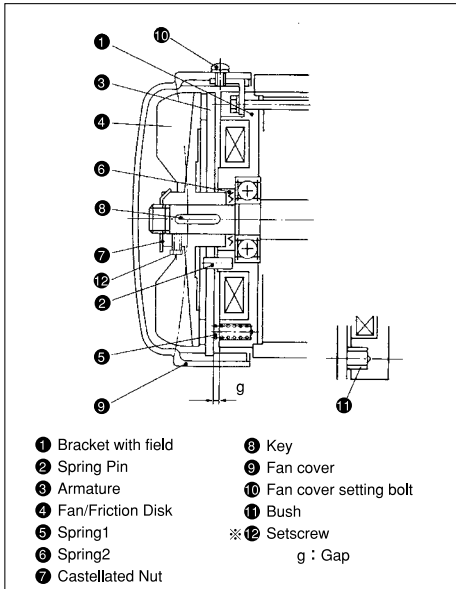

Motor Designation

3-phase/150•220•150W•220W

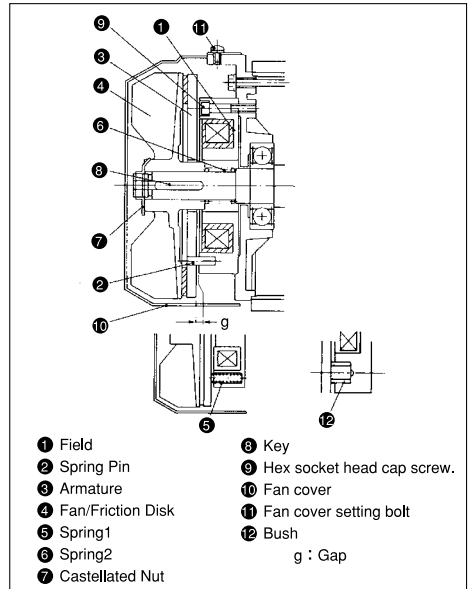

※Setscrew in ⑫ above is only for 1-phase motor.

Motor Designation		Inhalable Gap	Proper Gap
3-phase	Single-phase		
T010•T020•T010W•T020W	S100•100•200•S100W•100W•200W	g:2.3 and less	g:1.9±0.1
T040•T040W	—	g:1.8 and less	g:1.4±0.1
0.75•0.75W	400•400W	g:2.4 and less	g:2.0±0.1
150•220•150W•220W	—	g:1.0 and less	g:0.4±0.1

(2) Method for brake gap adjustment for gearmotor with brake/clutch

In the clutch and brake of this gearmotor, the automatic gap adjusting system which is our exclusive product, has already been installed. Therefore, gap adjustment caused by wearing is not necessary.

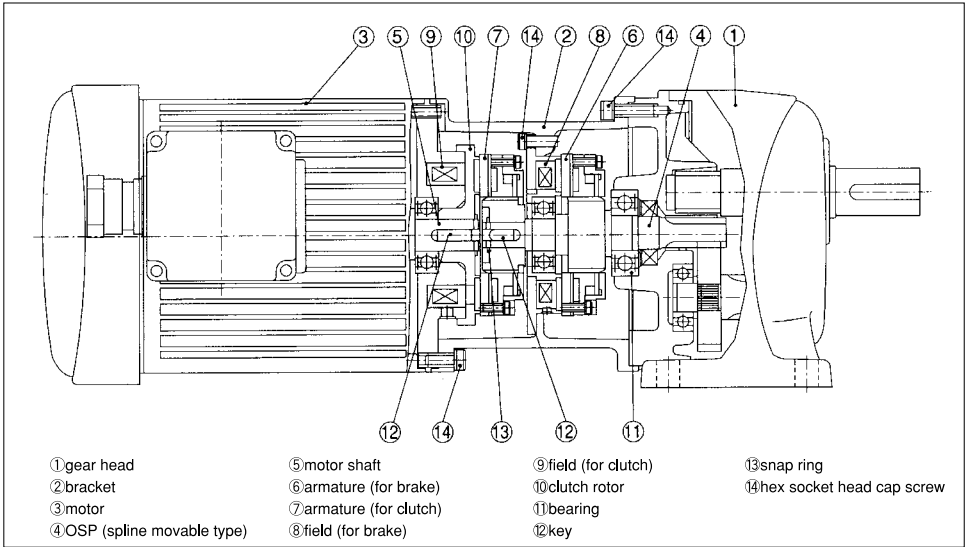

4 Warning Label

The warning label is attached in the gearmotors with brake manual release device. When the label peeled off or became hard to read, contact our sales office nearest to you.

5 Grease, Oil seal and O-Ring

- (1) GTR G3, H2, F, F2, F3 Series employ grease lubrication and they are sealed with determined quantity of lubricant when shipping from our factory. Therefore, machines are available for immediate use.
- (2) Replacement or refill of the lubricant is hardly necessary. However, replacing it once in 10,000 hours may help prolong the life of the reducers. For replacement of lubricant, be sure to use authorized factory.
- (3) Our machines are protected from grease leakage by oil seal or o-ring, however, it is recommended to protect the machine by oil pan for safety sake. Grease leakage may cause damage to the machine. (Grease leakage may be observed when machine is in trouble or at the end of life.)
- (4) The life of oil seal may vary according to the condition of use. Therefore replacement may be needed even within 10,000 hours use. For replacement of oil seal, be sure to use authorized factory.

9 Troubleshooting

1 Troubleshooting for gearmotor

Trouble	Cause	Troubleshooting
The motor does not run even in the unloaded condition.	Failure of power supply	Check the power source. Contact the power supply company
	Disconnection of wire	Check the electric circuit.
	Poor contact of switch	Repair or replace the relay.
	Disconnection of stator coil.	Repair at authorized factory.
	3-phase motor runs as single-phase motor	Check the terminal voltage.
	Capacitor connection forgotten(S100•S100W)	Connect capacitor
	Malfuction of governor switch(100•200•400)	Repair at authorized factory.
The motor does not run in the loaded condition.	Broken gear, shaft and bearing	Repair at authorized factory.
	Voltage drop	Check the length of wire.
	Worn out gear	Repair at authorized factory.
Abnormal rise in temperature	Overload operation	Reduce the load.
	Overload operation	Reduce the load.
	High frequency of start and stop	Reduce the frequency.
	Damage to bearings	Repair at authorized factory.
Abnormal noise	Overvoltage or low voltage	Check the voltage.
	Continued noise— defective bearing, worn out gear	Repair at authorized factory.
Excessive vibration	Intermittent noise—damaged gear or foreign substances inside the motor	Repair at authorized factory.
	Worn out gear or bearing	Repair at authorized factory.
Grease leakage	Improper installation or slacked bolts	Tighten the bolts.
	Loosened bolts/nuts/screws	Tighten the bolts/nuts/screws.
	Damaged oil seal	Repair at authorized factory.

2 Troubleshooting for gearmotor with brake

Trouble	Cause	Troubleshooting
Brake does not work	Wrong wiring	Check the wiring.
	Damaged switch	Replace or repair the switch
Brake function is not enough. Long braking time	Foreign substances or oil are adhered to the friction disk.	Remove foreign substances or oil or repair at authorized factory.
	Life of the friction disk.	Replace the friction disk or repair at authorized factory.
	Excessive moment of load inertia.	Reduce the load.
Motor does not run. (Rotating speed does not increase.) Overheated motor. Thermal relay trips. Abnormal noise in braking.	AC Switching wiring	Change to DC Switching wiring.
	Wrong brake wiring.	Check the wiring.
	Larger brake gap.	Adjust the brake gap.
	Failure of the rectifier.	Replace the rectifier.
	Disconnection or short circuit of brake coil.	Replace the brake coil, or repair at authorized factory.
Excessive rise in temperature.	Poor contact of switch.	Repair or replace the switch.
	High frequency of braking.	Reduce the frequency.
	Excessive load torque or moment of load inertia.	Reduce the load.

3 Troubleshooting for gearmotor with brake/clutch

Trouble	Cause	Troubleshooting
Clutch and brake do not work.	Wrong wiring	Check the wiring.
	Failure of the rectifier.	Replace the rectifier.
	Disconnection or short circuit of clutch/brake coil.	Repair at authorized factory.
	Defective switch	Repair or replace the switch.
Slow starting of rotation. Ineffective braking function.	Foreign substances or oil are adhered to the friction disk.	Remove foreign substances or oil. Or repair at authorized factory.
	Life of the friction disk.	Repair or replace the friction disk.
	Excessive load torque or moment of load inertia.	Reduce the load.

4 Parts for replacement

Contact our nearest sales office for the replacement brake parts. Please note that we will not warrant any defect caused by improper replacement done by customer.

10 Disposal

Caution

Gearmotors and lubricant should be disposed as general industrial waste.

11 Appendix

When using this gearmotor, attention should be given to the followings in addition to the items 1~10 previously described:

11-1 High-Efficiency Gearmotor for China

1 Target capacity

0.75kW, 1.5kW, 2.2kW

2 Certified Standard

This type is certified by the standard GB18613-2012.

This type is the grade 2 in the high-efficiency motor classification.

12 Warranty

1 . Warranty Term

The warranty term for the product shall be 18 months after the date of delivery or 12 month from the product starting operation, whether be shorter.

2 . Scope of Warranty

- 1) The scope of our warranty is limited to our manufacture.
- 2) In case that any failures on the product by which proper functions of the product cannot be obtained arise during the above warranty term, although the product is properly operated under the condition that the product is properly installed in, connected to the machine, treated (including inspection and maintenance) in accordance with this Instruction Manual, we will provide appropriate repair on the product free of charge, except as stipulated in the Exception for Warranty as described below.

3 . Exception for Warranty

This warranty shall not be applied to the problems, troubles or damages on the product which are caused by:

- 1) any repairs to the losses or damages caused by the disassemble, modification, change of parts or the substituted product delivered which are rendered by customer.
 - 2) customer's improper operation of the product not in conformity with the rated data specified in our catalogues or the specifications mutually agreed.
 - 3) any failures in the transmission part to customer's equipment (alignment of the shaft when coupling with other machine, etc.)
 - 4) disaster (earthquake, thunder, fire, flood, etc.) or human error such as wrong operation of the product.
 - 5) secondary failure caused by the damage of customers equipment.
 - 6) any losses caused by the parts, driving units (examples: electric motor, servomotor, hydraulic motor, etc.) which are supplied by customer.
 - 7) improper storage and maintenance of the product, or improper handling of the product.
 - 8) any other troubles, problems or damages on the product which are not attributable to our product liability.
 - 9) We are not responsible for the compensation against the loss of shutdown and/or for the damage to the equipments which are not produced by us, caused by the interruption of operation of our product.
- The items stipulated above are premised to apply to the transactions and use in domestic Japan. In case of the use in other countries, all the conditions are settled by the prior discussion between customer and our Sales Department.

【日本語版中型ギアモータ取説について】
 「GTR MID SERIES (0.1kW~2.2kW) ギアモータ取扱説明書」の、
 日本語版につきましては、下記URLにアクセスしていただき、
 取扱説明書PDFダウンロードページより、ダウンロードしてください。

http://www.nissei-gtr.co.jp/gtr/catalog/gtr-med_m.html

お問い合わせ窓口マップ

■ギアモータ製品の価格・納期に関するお問い合わせ(減速機事業部)

北海道・東北・関東甲信越地区のお客様

●東京営業所

〒103-0011 東京都中央区日本橋大伝馬町1番9号 日本橋大伝馬町プラザビル2F
 TEL(03)5695-5411(代表) FAX(03)5695-5418
 E-mail tokyo@nissei-gtr.co.jp

●東北出張所

〒980-0811 宮城県仙台市青葉区一番町1-5-16 SEビル7F
 TEL(022)281-8421 FAX(022)281-8431

近畿・中国・四国・九州・沖縄地区のお客様

●大阪営業所

〒541-0052 大阪府大阪市中央区安土町2-3-13 大阪国際ビルディング6F
 TEL(06)6210-1157(代表) FAX(06)6210-2507
 E-mail osaka@nissei-gtr.co.jp

●九州出張所

〒812-0016 福岡県福岡市博多区博多駅南1-3-1 日本生命博多南ビル7F
 TEL(092)409-7385 FAX(06)6210-2507

東海・北陸地区のお客様

●中部営業所

〒444-1297 愛知県安城市和泉町井ノ上1-1
 TEL(0566)92-7410(代表) FAX(0566)92-7418
 E-mail honbu@nissei-gtr.co.jp

●海外向けのお問い合わせ

●海外営業部

〒444-1297 愛知県安城市和泉町井ノ上1-1
 TEL(0566)92-5312(代表) FAX(0566)92-7002
 E-mail oversea@nissei-gtr.co.jp

■歯車製品に関するお問い合わせ(歯車事業部)

●営業部

〒444-1297 愛知県安城市和泉町井ノ上1-1
 TEL(0566)92-5251 FAX(0566)92-4770
 E-mail gearsale@nissei-gtr.co.jp

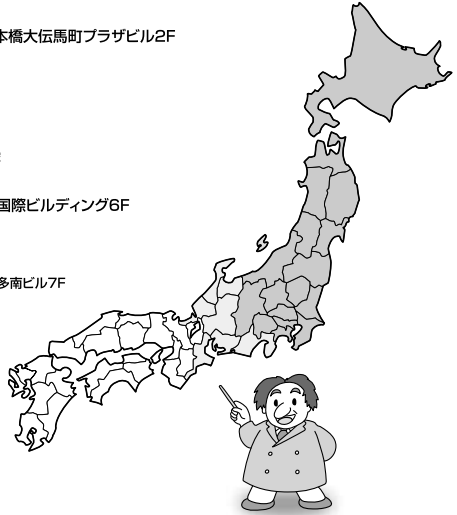



“CSセンター”のご案内

ワン・ストップコール!! 下記電話番号までお電話ください。
 専任担当デスクが、お客さまのいろいろなご相談にお応えします。



お客様技術相談デスクで…

「技術上のご質問にお応えします!」

■ギアモータの選び方・使い方・お困りごとのご相談
 ■特注仕様品のご相談 ■機種選定サービス

tel:0120-889-867 fax:0120-316-565 email:tech-cs@nissei-gtr.co.jp
 ※Web機種選定サービスは24時間ご利用可能です。http://www.nissei-gtr.co.jp/



CRMデスクで…

「新製品情報をご提供します!」

直通 tel:0566-92-5797 fax:0120-814-447 email:cs@nissei-gtr.co.jp

■製品カタログのご請求

■eDMについてのお問い合わせ

■情報発信システムへのお問い合わせ

NISSEI CORPORATION

Sales, Overseas Division

1-1 Inoue, Izumi-cho, Anjo-shi, Aichi, 444-1297 JAPAN

TEL: +81-566-92-5312 FAX: +81-566-92-7002