

High Stiffness Reducer Detailed Instruction Manual

<Please read this manual before using the product.>

Introduction



Thank you very much for purchasing our product.
The detailed instruction manual can be downloaded by scanning the QR code or accessing the URL shown below.

Name	
High Stiffness Reducer Detailed Instruction Manual	
Link to material	
Homepage	QR Code
https://img-jp.nissei-gtr.co.jp/files/user/pdf/data/gtr/manual/rc/rc_e.pdf	

Safety Precautions

- Be sure to carefully read the contents described in this Instruction Manual to master how to use the product correctly before using it.
- Extents of hazard/damage expected to occur in the case of improper handling are classified and indicated into ranks of "DANGER", "WARNING", and "CAUTION" in this Instruction Manual.

Description of the symbol

	DANGER	Cases where it is expected that a degree of danger is extremely high such that improper handling possibly causes a dangerous situation to occur, which may lead to death or serious injury.
	WARNING	Cases where improper handling possibly causes a dangerous situation to occur, which may lead to death or serious injury.
	CAUTION	Cases where improper handling possibly causes a dangerous situation to occur, from which a minor or medium degree of injury may be incurred.

Even items described in "CAUTION" may lead to a serious accident depending on the situation.
Be sure to observe every instruction which deals with important contents.

The types of precautions to be observed are explained with classification, per the symbols below.

	Indicates "What You Must Pay Attention To."		Indicates "What You Must Not Do."
	Indicates "Burn Hazard."		Indicates "Do Not Disassemble."
	Indicates "Fire hazard."		Indicates "What You Must Do."

Installation

Installation Environment	
Ambient Temperature	0°C~40°C
Ambient Humidity	85%RH max (No Condensation)
Altitude	1,000m or lower
Atmosphere	A well-ventilated place free from corrosive gas, explosive gas, vapor, chemicals, etc. Not to be exposed to direct rain. Not to be exposed to direct sunlight. Well-ventilated place free from dust.

Installation Procedure

- Secure the reducer with bolts on a flat machine-processed and vibration-free surface.
- Tighten the bolts with the tightening torque as shown in the table below.
- If the foundation is bad or the mounting surface is not flat enough, vibration may occur during operation and the service life of the reducer may be shortened.
- Make sure the flatness of the mounting surface is 0.1 mm or less.
- Use washers for the bracket for the Flat (DGF type) so that it does not come into direct contact with the bearing surfaces of the bolts.

[Reference] Refer to the figure [Flat (DGF type) O-ring mounting position] for the relevant sections.

Bolt size	Tightening torque (N·m)
M3	2.4
M4	5.4
M5	10.8
M6	18.4

[Reference] The bolt strength class (JIS B 1051) is 12.9.
Recommended bolt: Hex Head Cap Screw (JIS B 1176)







Precautions for the Hollow Bore (DGH type)

Lubricant / seal material

- Grease is sealed in the reducer at the time of shipment from our factory. Since oil seals and O-rings are already fixed to the input shaft, the product is ready to be operative.





DANGER

General



-   If the product is used in an application such as a personnel transport device, make sure to install a protective device for safety purposes. Failure to implement safety measures may result in personal injury, death, and/or damage to the application.
-   If the product is used in an elevator, install a safety device on the application to prevent it from falling. Failure to implement safety measures may result in personal injury, death, and/or damage to the application due to the falling of the elevator.
-   Do not use the product in an explosive environment. Failure to observe this precaution may result in explosion, ignition of fire, fire, electric shock, injury, or damage to the application.

WARNING



General

-   The operators in charge of installation, operation, handling, maintenance, and inspection should have enough knowledge and technical skill related to the product. Failure to follow this precaution may result in injury and damage to the application.
-   Do not repair, disassemble, or remodel the product. Failure to follow this precaution may result in injury.

Transportation and Installation











-   During transportation or installation, do not step under the mounted product. Failure to follow this precaution may result in injury accidents due to dropping.

Operation







-   When the operation has stopped due to the occurrence of error, do not re-start the operation until the causes of error are determined and countermeasures are taken. Failure to follow this precaution may result in damage to the application, injury, fire, electric shock, and/or burns.

CAUTION

General













-   During inspections, please ensure that all components that are connected/mounted to the product and the product itself are at a complete stop. Failure to follow this precaution may result in damage to the application and/or injury.
-   Operate the product under the conditions specified in this instruction manual. Failure to follow this precaution may result in damage to the application and/or injury.
-   Do not expose the product to strong impacts/shocks. Failure to follow this precaution may result in failure of the product and/or injury.
-   Make sure the reducer surface temperature does not exceed 80°C. Failure to follow this precaution may result in damage of the product and/or burn injury.
-   Do not erase the laser marking.

Transportation







-   The product must be transported correctly in accordance with its weight. Failure to follow this precaution may result in injury and/or malfunction.
-   Do not overload/over stack the products. Failure to follow this precaution may result in injury and/or malfunction.
-   Do not hold the input shaft during transportation. Failure to follow this precaution may result in damage to the application and/or injury.

CAUTION













Installation

-   When handling the product, be careful with the sharp edges/points of the product. Failure to follow this precaution may result in injury.
-   This product shall be fixed on the machine securely. Failure to follow this precaution may result in damage to the application and/or injury.
-   Do not put any combustible material near the product. Failure to follow this precaution may result in fire.
-   Do not put any object that may prevent air from being circulated around the product. Failure to follow this precaution can cause abnormal overheating of the product. It may result in fire or burns.
-   Do not stand on or place any heavy object on the product. Failure to follow this precaution may result in injury.
-   Do not tap on the axis of rotation. Failure to follow this precaution may result in damage to the equipment.

Operation

-   Please mount the product on a flat surface with no vibration. Failure to follow this precaution may result in damage to the product.
-   Install an oil pan or other preventive device in oil-sensitive machinery, such as food machinery, just in case oil leaks because of failure, service life, etc. Otherwise, products may be defective due to oil leakage.
-   Confirm the rotational direction before connecting to your device. Incorrect rotational direction may result in injury or damage to the device.

Transportation

-   Immediately stop the operation if there is any abnormality. Failure to follow this precaution may result in electric shock, injury, and/or fire.
-   Do not touch the reducer during operation and/or immediately after a stop as its surface may be hot for a while. Failure to observe this precaution may cause burns.
-   Make sure to maintain the surface temperature below 80°C upon continuous operation in one direction and frequent startup/stop operation under a high load. Failure to follow this precaution may result in damage to the product.
-   Do not touch the rotating part of the product. Failure to follow this precaution may result in injury.
-   Avoid applying torque in excess of the allowable maximum instantaneous torque. Failure to follow this precaution may result in damage to the application and/or malfunction.
-   Do not use in an environment with metallic dust around. Failure to follow this precaution may result in damage to the product.

Important Note

When disposing of the product, dispose of it as a general industrial waste. Please follow local laws and regulations if any apply and take care of the waste accordingly.

Notice

NISSEI CORPORATION accepts no responsibility or liability for any troubles caused by abnormal usage that violates the cautions listed in this manual.

The contents of this manual are subject to change without notice.

We have made every possible effort to make the contents of this manual easy to understand. If there is anything that is unclear or hard to understand, please feel free to contact us.

Inspection upon Unpacking

Checking the Contents of the Package

Check the following items after unpacking.
If there are any defects, or if you have any questions, please contact your nearest service office immediately.

- Please check whether the information on the laser marking is matching with your order?
(Reducer Part Number, Reduction Ratio)
- Were any parts damaged during transportation?
- Are there any loose screws or bolts?
- Do the accessories included in the package match the contents of the accessories list?
(The accessories list will not be included in the package if there are no accessories.)

Information on laser marking

The laser marking is provided on the side face of the product.
Typical laser markings are shown below.

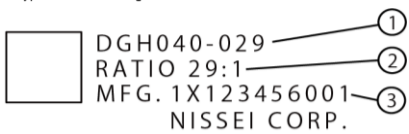

No.	Description
1	Part Number
2	Reduction Ratio
3	Manufacturing Number

Part Number

Below is the information on type codes.
Confirm that the part number matches your order.

[1]	[2]	[3]	[4]	[5]
DG	H	040	-	029

No.	Item	Type Code	Description
[1]	Model	DG	DG Series
[2]	Type	H	Hollow Bore
		F	Flat
		S	Solid
[3]	Frame Size	H	010, 030, 040, 080, 150
		F	005, 020, 030
		S	010, 030, 050
[4]	Reduction Ratio	H	019, 029, 059 1/19, 1/29, 1/59
		F	050, 100 1/50, 1/100
		S	019, 029, 049, 079, 099, 119 1/19, 1/29, 1/49, 1/79, 1/99, 1/119*1
[5]	Option	Blank	Standard Specification
		X	Special Specification Code

*1 Reduction ratio 1/119 applies only to Frame Sizes 030 and 050.

Precautions for the Flat (DGF type) / Solid (DGS type)

Lubricant / seal material

- Grease is sealed in the reducer at the time of shipment from our factory. However, oil seal is not fixed to the Device-side input shaft. If necessary, attach a seal to the device to prevent grease leakage.
[Reference] Refer to the figure [Installation example] of each type for an example of seal mounting.
- Enclose our exclusive grease (sold separately) in 70 to 80% of space between reducer and the device.
[Reference] Refer to the figure [Installation example] of each type for an example of grease enclosure.
- For the Solid (DGS type), enclose our exclusive grease (sold separately) in the reducer as well.
[Reference] Refer to the figure [Solid (DGS type) Installation example] for the enclosing positions.
[Reference] Refer to the table [Enclosing amount for reducer grease enclosing position] for the enclosing amount.

Manufacturer / Product name	thickener	base oil	Density
Chukyo Kasei Kogyo Co., Ltd. R2 Grease TA-00 V19	lithium soap	mineral oil synthetic oil	0.9g/cm ³

Precautions for grease sealing

- Not using above grease and Not filling designated amount may result in performance reduction and early damage.
- Take care to prevent dust, moisture, etc. from mixing in. Failure to follow this precaution may result in damage to the product.

■ Calculation example of grease enclosing amount for device-side grease enclosing position

When the spatial volume of the device side is 24 cm³

$$\begin{aligned} \text{Device-side grease enclosing amount} &= \text{<Spatial volume>} \times 24 \text{ cm}^3 \\ &\times \text{<Grease density>} \times 0.9 \text{ g/cm}^3 \\ &\times \text{<Filling ratio>} \times 75\% \\ &= 16.2\text{g} \end{aligned}$$

- When installing this product please make sure to utilize the O-rings(2 Types).
[Reference] Refer to the figure [O-ring mounting position] of each type for the mounting positions of the O-rings.

Precautions for the O-ring

- Before using, make sure that there is no damage on the O-ring.
- When mounting the O-ring, take care not to allow adherence or entry of foreign substances and dust.
- When mounting the O-ring, make sure it does not get twisted or pinched.
- The O-ring contact surface of your device shall have surface roughness of Ra 1.6 or less (Rz 3.2 or less).
- Although the applied oil may ooze out when the supplied O-ring is mounted, this will not cause any performance issues.

Engagement of reducer and device * Solid (DGS type) only

- Use either a screw-locking adhesive with an effective seal or sealing screws for engaging the device-side driven shaft and the reducer. When the screw holes of the device-side driven shaft are not completely sealed, the grease may leak out.
[Reference] Refer to the figure [Solid (DGS type) Installation example] for the engagement of the device-side driven shaft and the reducer.
- Frame Sizes 010 and 030 come with hexagon socket set screws (M3x3L, 2 pieces). Use them to fix the device-side input shaft. The tightening torque is 0.66 N · m.
- Adjust the gap between the end face of the device-side input shaft and the reducer with shims, etc.
[Reference] Refer to the figure [Solid (DGS type) Installation Example] for the relevant sections.

Reference figures and tables for Flat (DGF type) / Solid (DGS type)

Figure [Flat (DGF type) Installation example]

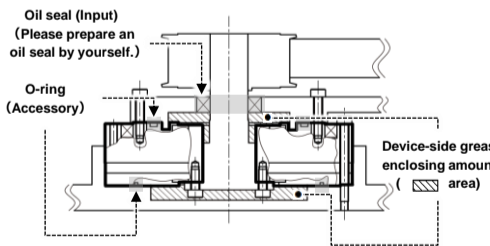
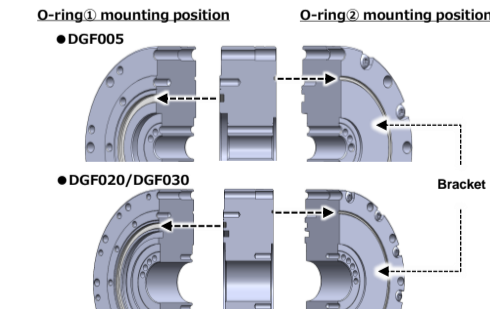

Figure [Flat (DGF type) Installation example]



Part Number	O-ring part number	
	O-ring ①	O-ring ②
DGF005 - * * *	33.5x37.5x2 (S-34)	48x50x1
DGF020 - * * *	44.5x48.5x2 (S-45)	58x60x1
DGF030 - * * *	54.5x58.5x2 (S-55)	68x70x1

Figure [Solid (DGS type) Installation example]

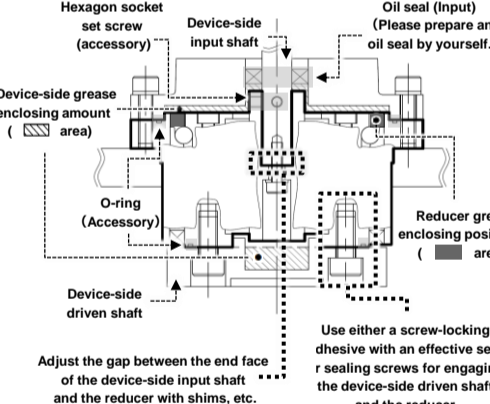
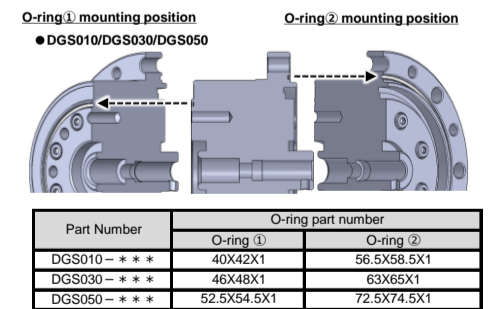

Table [Enclosing amount for reducer grease enclosing position]

Part Number	Grease enclosing amount[g]
DGS010 - * * *	1.6
DGS030 - * * *	2.1
DGS050 - * * *	2.5

Figure [Solid (DGS type) O-ring mounting position]



Part Number	O-ring part number	
	O-ring ①	O-ring ②
DGS010 - * * *	40x42x1	56.5x58.5x1
DGS030 - * * *	46x48x1	63x65x1
DGS050 - * * *	52.5x54.5x1	72.5x74.5x1

Precautions for the dedicated grease (sold separately)

- Avoid direct sunlight and store in a well-ventilated place.
- Please check the Safety Data Sheet (SDS) before use.

Maintenance

- All the models that we offer use a grease lubrication system; they do not need grease replacement/replenishment.
- For repair, please contact your nearest Sales Office.

Periodic Inspection

Product inspection items are described in the table below.

Based on the inspection guideline, determine the best inspection timing by considering the usage and environment.

Inspection items	Inspection Frequency	Inspection and maintenance procedure
Checking the connection with the machine	Before starting operations	<ul style="list-style-type: none"> Make sure that the product-machine mounting screws are tight enough. Make sure that the connection between the product and its load side is firm and not loose. Check for misalignment.
Vibrational and acoustic check	Every day	<ul style="list-style-type: none"> No increase from the normal level.
Appearance check	Whenever required	<ul style="list-style-type: none"> Perform cleaning with a cloth, compressed air, etc.
Surface Temperature	Every day	<ul style="list-style-type: none"> Make sure the surface temperature of the reducer does not exceed 80°C. Check that there is no rapid increase or decrease from normal temperature.
Checking for grease leakage	Every two to three days	<ul style="list-style-type: none"> Make sure that the connections of the product case, oil seal, bracket, etc. are with no leakage.

Storage

1.Storage Location

- When the product is stored, it shall be stored indoors in a dry place with good ventilation, without direct sunlight, extreme temperature change, humidity, dust, and/or corrosive gas.
- Do not place the product directly on the ground when it is stored.
- If there are micro-vibrations, the bearings may be damaged by fretting corrosion even when the product is stored. Please store the product in a place free of vibration.

2.Operation during Storage

- To prevent the bearings from getting rusty, operate the product every six months to check if the product rotates smoothly and there is no abnormal sound.
- Apply rust prevention to the rotating shafts, flange surface, and any other uncoated, processed surfaces every six months.

3.Usage after Storage

- Check that there is no abnormal sound, vibration, heat generation or other abnormalities during initial operation.

Warranty

1.Warranty Period

18 months from the factory shipment date or 12 months after installation; whichever ever that comes first.

2.Warranty Coverage

- The warranty coverage is limited to our production range.
- If a failure that prevents function of the delivered product occurs under the conditions with normal installation/connection and handling (inspection/maintenance) described in this instruction manual during the warranty period, the product will be repaired without any additional cost. However, NISSEI CORPORATION will not be liable for any costs for removing or installing our products from the user's device for replacement or repair, costs for transportation for repairs, and/or indirect damages.

3.Warranty Exclusions

- Repair, parts replacement, or delivery of alternative products to handle product wear resulting from disassembling or remodeling by customers.
- When the product is operated under conditions that are outside of the rated data described in our catalog/instruction manual or specifications mutually agreed.
- When there is a defect(centering of coupling etc.) in the power transmission part with the customer's device.
- When inevitable accidents such as extraordinary natural disaster (Example: Earthquake, lightning, fire, and flooding) or malfunction (caused by human error) become the cause of failure.
- Secondary failure caused by defects of customer's equipment.
- Failure resulted from parts and drive units that are designated or supplied by the a customer (e.g.motor, servo motor, hydraulic unit, etc.)
- When storage, maintenance management of the delivered product is not performed properly and handling is not carried out correctly. (For storage, see "Storage".)
- Failure due to items that cannot be attributed to our manufacturing responsibility other than the above.

Contact Us

■ Inquiries about quote, purchase, repair, and inspection

Overseas Sales	
Address	1-1 Inoue, Izumi-cho, Anjo, Aichi 444-1297, Japan
Tel	+81-566-92-5312
Fax	+81-566-92-7002
E-mail	oversea@nissei-gtr.co.jp

2024/2
Ver.2.0

NISSEI CORPORATION

Web site URL : <https://www.nissei-gtr.global/en/>